

**High Temperature
 Shutdown System
 Model ZT-100**

GENERAL DESCRIPTION

The ZT-100 Series self-actuated Temperature Shutoff System offers an improved means of monitoring heated liquid temperatures and initiating preventative action in the event of a temperature overshoot or accidental damage to the system. It is installed in connection with controlled water heaters of the storage or instantaneous type (see "Instantrrol" Heater Package), where an extra degree of precaution against the discharge of overheated liquid is important.

The ZT-100 system consists of a single-seated diaphragm control valve, a temperature sensitive pilot with a manual relatch feature, and a combination pressure regulators trainer-relief valve. The system operates on the cold water supply pressure and requires no electrical or pneumatic supplies. Loss of cold water supply closes the system down. Piping is completed at installation as illustrated in Fig. 1A or B.

SPECIFICATIONS

PILOT VALVE:

- Type: Three-way
- Ends: 1/2" NPT
- Port: 3/16"
- Medium: Cold water
- Thermal System: Fail-Safe
- Capillary: 6 ft. standard, copper
- Bulb: 12B (bushed) 1/2" x 3-7/8" copper
- Well: Available on order in S. S. 1/2" NPT mounting thread, 4-7/32" insertion.

Range Selection:

- 100 - 128°F
- 125 - 140°F
- 135 - 165°F
- 160 - 190°F
- 180 - 210°F

Setpoint: Adjustable

REGULATOR/STRAINER RELIEF VALVE

REGULATOR:

- Ends: 1/2" NPT
- Range: 10-25 psig
 (factory set 12 psig)
- Max. Pressure: 125 psig

RELIEF VALVE:

- Ends: 1/2" NPT
- Pressure Setting: 30 psig



83418-A1



VC231A-MA



I-530-M1

HOW TO ORDER

Specify:

1. Control valve size.
2. Pilot range and setpoint.
3. Medium.
4. Supply pressure and pressure drop through control valve.

DIAPHRAGM SHUTOFF VALVES (VC231A-MA)

LINE SIZE	VALVE SIZE	MATERIAL		MAX. SUPPLY		MAX. PRESSURE DROP
		BODY	TRIM	WATER	STEAM	
3/4"	3/4"	BZ	SS	250	250	250
1"	1"	BZ	SS	250	250	250
1-1/4"	1-1/4"	BZ	SS	250	250	250
1-1/2"	1-1/2"	BZ	SS	250	250	250
2"	2"	IRON	SS	125	125	125

OPERATION

With the temperature sensing bulb of the pilot installed in the heated water line, the latched open pilot supplies a 12 or 20 psi pressure to the shutoff valve diaphragm so that the valve remains in the full-open position.

If the shutoff valve is installed in the heated medium line, liquid is allowed to flow on demand as long as the temperature at the pilot sensing bulb is below the pilot setpoint. If the liquid temperature exceeds the setpoint, the pilot vents the pressure on the shutoff valve diaphragm and the shutoff valve immediately closes and stops the liquid flow. The condition causing the over-temperature must be corrected and the pilot manually relatched before monitored service is restored.

If the shutoff valve is installed on the heating medium supply line, then the supply to the heater is shut off when or if a temperature over-run is detected at sensing bulb, but the liquid flow is not affected.

Damage or failure of the thermal system of the pilot results in closure of the shutoff valve on either line.

DIMENSIONS

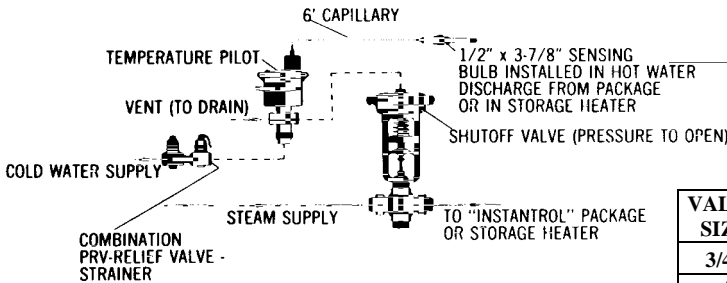
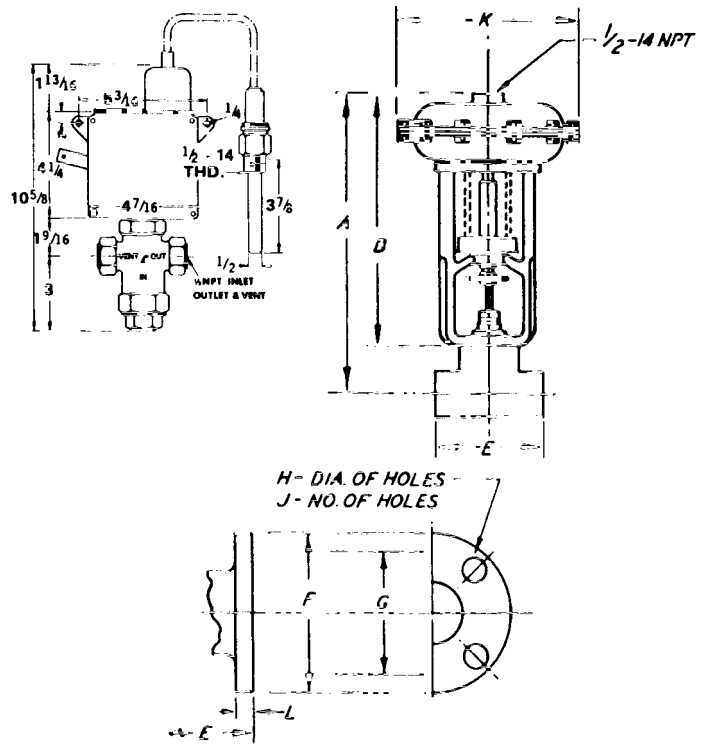

Fig. 1A - With Shutoff valve installed in steam supply line.

SHUTOFF VALVE DIMENSIONS

VALVE SIZE	DIMENSION								
	A	B	K	E	F	G	H	J	L
3/4"	14-5/16"	10-7/8"	9-1/2"	6-15/16"	-	-	-	-	-
1"	14-5/16"	10-7/8"	9-1/2"	7-1/8"	-	-	-	-	-
1-1/4"	14-1/2"	10-7/8"	9-1/2"	7-1/2"	-	-	-	-	-
1-1/2"	15"	10-7/8"	9-1/2"	8-1/2"	-	-	-	-	-
2"	15-13/16"	10-7/8"	9-1/2"	7"	6"	4-3/4"	3/4"	4"	5/8"

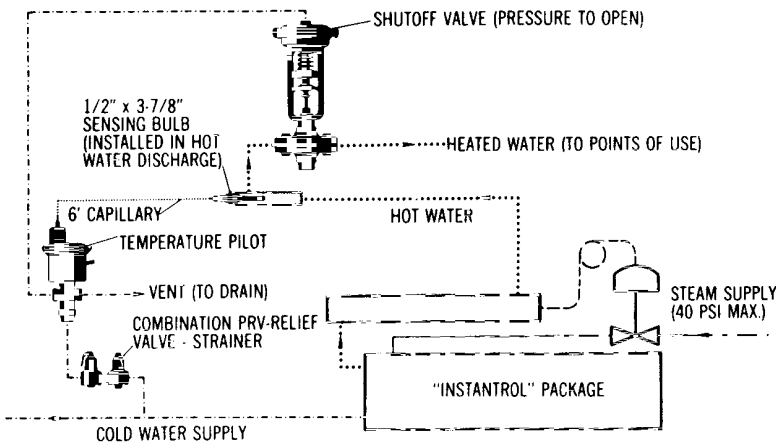

Fig. 1B - With Shutoff valve installed in hot water discharge line.

NOTE: Setpoint must be higher than ambient temperature surrounding the pilot and its capillary. Pilot and its sensing bulb should be installed several feet downstream from heater outlet.

Schneider
Electric Systems USA, Inc

1602 Mustang Dr
Maryville, TN 37801
Ph (865) 981-3100
FX (865) 981-3168