

Side Mounted Valve Positioner Model P2

GENERAL DESCRIPTION

The Model P2 Pilot Positioner is a positive positioning relay for use with pneumatically operated valves and actuators. This unit positions the valve, correcting for such factors as stem friction or valve loading by sensing the true stem position through the feedback lever and utilizing as much of its independent air supply as is necessary to achieve the true valve position represented by a 3 to 15 psig (0.2 to 1.0 bar) instrument pressure.

The positioner is sturdily constructed of aluminum and stainless steel with Buna-N nylon diaphragms to ensure a long, trouble-free operating life.

SPECIFICATIONS

- Action:** Proportional, Direct-Acting.
- Supply Air Pressure:**
- Nominal* 18 psig (1.25 bar)
 - Maximum* 30 psig (2.0 bar)
- Instrument Pressure:** 0 to 15 psig (0 to 1.0 bar)
- Adjustments:**
- Throttling Range* Field adjustable 3 to 12 psig (0.2 to 0.8 bar)
 - Start Point* Field adjustable 3 to 12 psig (0.2 to 0.8 bar)
- Repeatability:** 0.9% of full range.
- Maximum Air Consumption:** 3.5 SCFH.

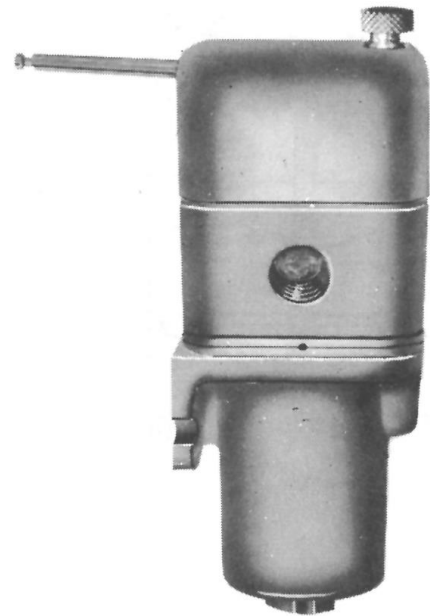

GENERAL INSTRUCTIONS

TO BE USED ON CONTROL AIR ONLY. DO NOT USE ANY OTHER MEDIUM.

1. This positioner will operate properly when mounted in any position.
2. Do not remove the protective plastic plugs until just before making the connections.
3. Feedback springs are designed for specific valve strokes (See table below). If it should be necessary to move this positioner to a valve having a different stroke, care should be taken to use the correct spring. Springs may be obtained from the factory by ordering part number listed.

ORDERING INFORMATION

- Specify:
1. Model Number.
 2. Serial Number of Control Valve to which it is mounted.

VALVE STROKE	1/4" to 3/8" (6.4 to 9.5 mm)	7/16" to 5/8" (11 to 15.9 mm)	11/16" to 1" (17.5 to 25.4 mm)	1-1/16" to 1-7/16" (27 to 36.5 mm)	1-1/2" to 2" (38 to 50.8 mm)
SPRING	29448-A1	29448-B1	29448-C1	29448-D1	29448-E1
COLOR CODE	BLACK	NONE	ORANGE	RED	WHITE

INSTALLATION

Utilizing the two mounting slots shown in Figure 1, bolt the positioner to the valve or actuator.

Attach the feedback spring, making sure that the valve stroke and the spring are matched. There should

be approximately 1/4 pound (114 g.) load on feedback spring when valve starts to move.

Connect the air lines to the proper ports as shown in Figure 1.

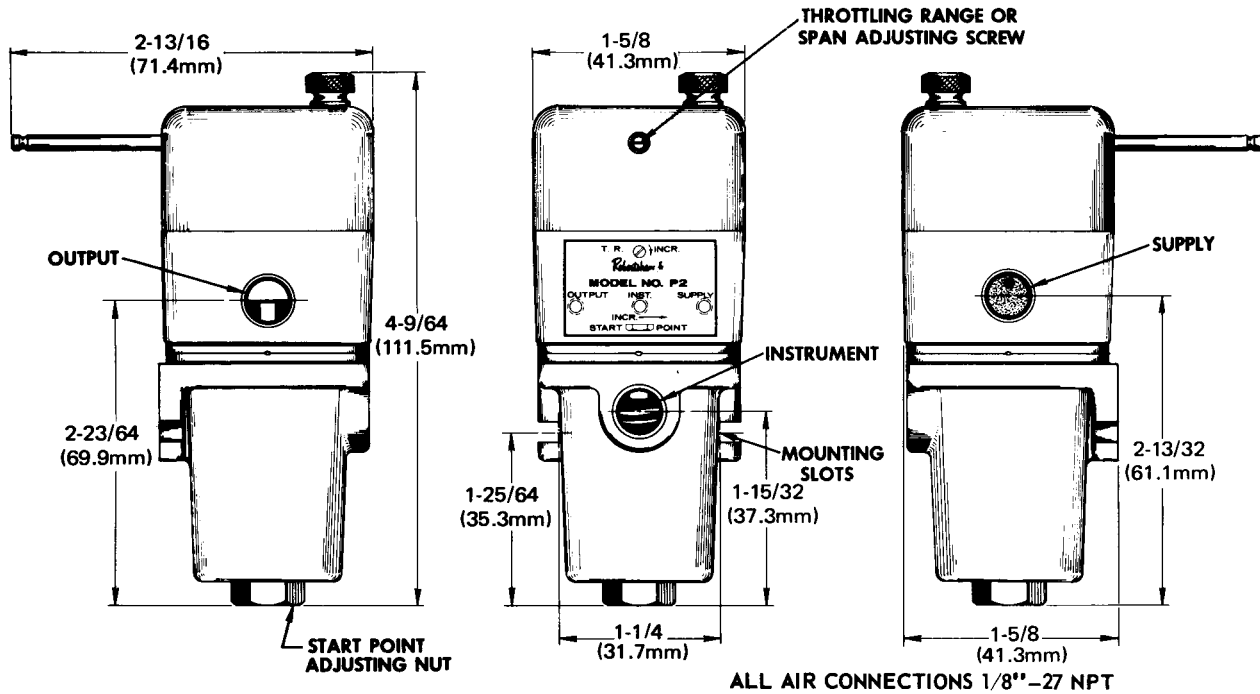

Figure 1

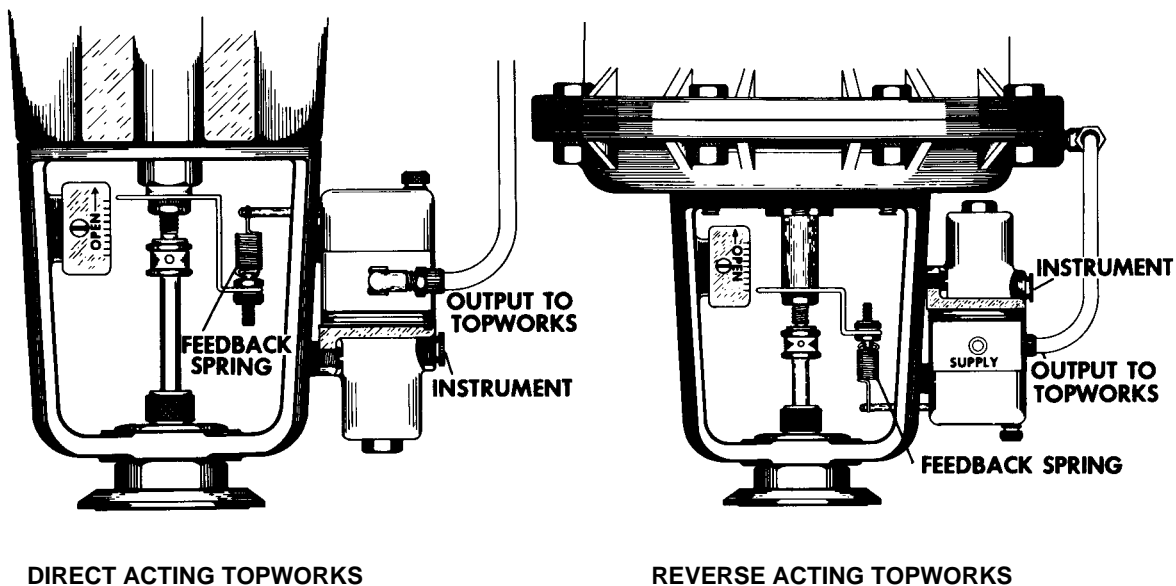

Figure 2

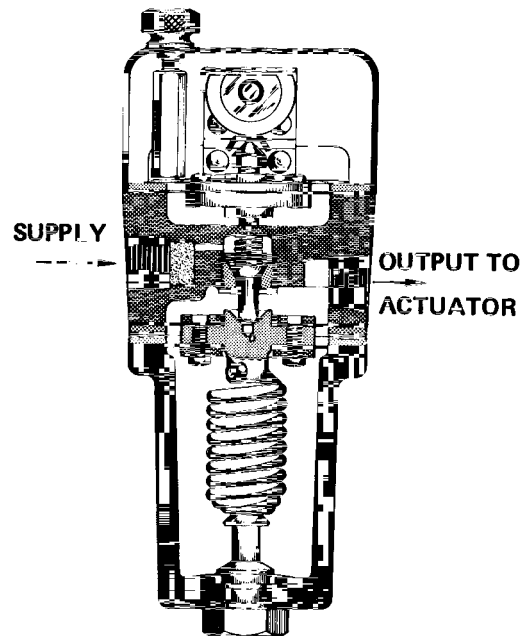
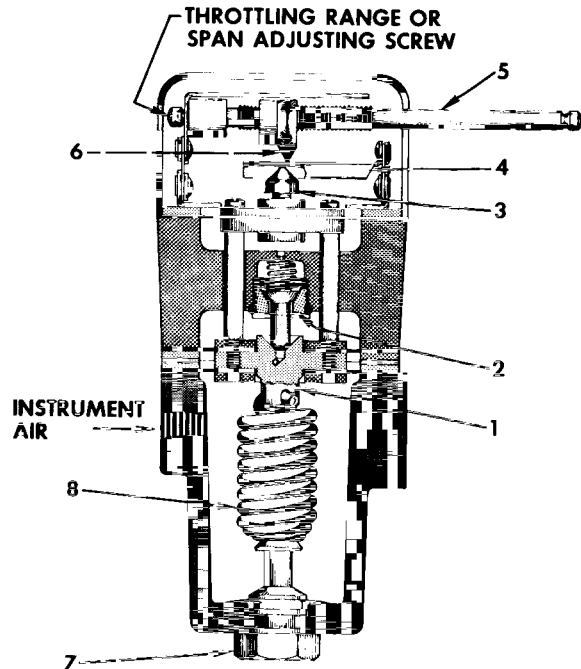

Figure 3

OPERATION

With the start Point Adjusting Nut (7) at the desired setting, introduction of instrument pressure creates an upward force against the Valve Seat Assembly (1). When the instrument pressure exceeds the downward force of the Start Spring (8), the Valve Seat Assembly (1) is forced upward unseating the upper (larger) hemispherical surface of Valve (2). This opens the passage between the Supply and Output chambers allowing supply air to flow into the output chamber and out to the Actuator Diaphragm Chamber.

The motion of the Valve Seat Assembly (1) is also transmitted to Pivot (3) acting against Arm (4). This arm transmits the movement to Feedback Lever (5) which is connected by a spring to the terminal control valve stem. Through this linkage, motion of the control valve stem is fed back to the Valve Seat Assembly (1).

Increasing output pressure moves the control valve stem downward, increasing the spring force downward against the Valve Seat Assembly (1).

Rotation of Lever (5) moves Pivot (6) along Arm (4) thereby adjusting the throttling range of the control. Therefore, the movement of the control valve stem is proportional to the instrument pressure change and the downward force transmitted to the Valve Seat Assembly equals the upward force of the instrument pressure and both surfaces of Valve (2) are seated.

Any reduction of the instrument pressure causes an unbalance, allowing the valve seat assembly to move downward, opening the lower surface of the Valve (2) and exhausting Control Valve Diaphragm air pressure until the control valve stem has moved upward a proportional amount.

ADJUSTMENTS

Vary the instrument pressure over the range and turn the throttling range adjusting screw until the desired throttling range is achieved in stroking the valve.

Then, with the instrument pressure at the desired start point, turn the start point adjusting nut (Figure 1) until the valve just begins to move.

MAINTENANCE AND REPAIR

The design of the Model P2 makes routine maintenance unnecessary.

It is recommended that no field maintenance be attempted on the device other than replacement of the filter beneath the supply air connection.

If repair becomes necessary, replace the unit with a new or factory reconditioned unit.

Schneider
 **Electric Systems USA, Inc**

1602 Mustang Dr
Maryville, TN 37801
Ph (865) 981-3100
FX (865) 981-3168

Q-3275 (1/19)

Printed in U.S.A.