

Summation Relay

CR-104-A3, CR-104-A5

DESCRIPTION

The model CR104 Summation Relays are proportioning units designed for use in industrial pneumatic control systems where the application requires delivery of an output pressure signal which is the sum and/or differences of two to five pneumatic input pressure signals introduced into the unit. For further details, see page 2.

MODELS AVAILABLE

- CR104-A3: 3 input signals (add 2, subtract 1).
- CR104-A5: 5 input signals (add 3, subtract 2).

SPECIFICATIONS

DESIGN DATA

Input Pressure Range:

- 0-20 psig (0-1.4 bar) nominal
- 0-50 psig (0-3.5 bar) maximum

Output Pressure Range:

- 0-20 psig (0-1.4 bar) nominal
- 0-50 psig (0-3.5 bar) maximum

Supply Pressure:

- 30 psig (2.1 bar) nominal
- 50 psig (3.5 bar) maximum

Biasing Adjustment: ± 18 psig (1.2 bar)

Ambient Temperature Limits:

-40 to 180 F. (-40° to 82° C.)

Connections: 1/4" female NPT

Weight:

- CR104-A3 2.1 lbs. (0.95 Kg)
- CR104-A5 2.3 lbs. (1.04 Kg)



PERFORMANCE DATA

Ultimate Sensitivity:01 in. H₂O

Supply Pressure Effect:

Change in output pressure for a 5 psig (0.35 bar) supply pressure change - less than 1 % of full range.

Ambient Temperature

Effect:

Change in output pressure for a 75 F. (24° C.) change in ambient temperature - 0.5% of full range.

Air Consumption: 6.0 SCFH maximum.

For Maximum Flow:

Supply Output Capacity 3.0 SCFM

Exhaust Output Capacity 3.0 SCFM

ORDERING INFORMATION

OPERATION	MODEL NO.
Add two, subtract one	CR104-A3
Add three, subtract two	CR104-A5

FUNCTION

The operation of the three-signal unit, Model A3, is described by the equation:

$$P_0 = P_5 + P_3 - P_1 \pm F_s$$

The operation of the five-signal unit, Model CR104-A5 is described by the equation:

$$P_0 = P_3 + P_5 + P_6 - P_1 - P_4 \pm F_s$$

Where:

P₀ is output pressure

P₁, P₆, P₃, P₄ and P₅ are input pressure signals.

(The subscript refers to ports as marked in Figures 1 and 2.

F_s is the biasing spring force.

For example, if each of the input pressure signals is 5 psi (0.35 bar) and the biasing spring is preset at zero force:

For CR104-A5 -

$$P_0 = P_3 + P_5 + P_6 - P_1 - P_4 \pm F_s$$

$$P_0 = 5 + 5 + 5 - 5 - 5 \pm 0$$

$$P_0 = 5$$

For CR104-A3 -

$$P_0 = P_5 + P_3 - P_1 \pm F_s$$

$$P_0 = 5 + 5 - 5 \pm 0$$

$$P_0 = 5$$

By omitting some of the input pressure signals (leaving them at atmospheric pressure) equations with fewer inputs can be solved as follows:

MODEL	ADD	SUBTRACT	EQUATION	0 PSI SIGNALS
CR104-A3	2	0	$P_0 = P_5 + P_3 \pm F_s$	P ₁
CR104-A3	1	1	$P_0 = P_5 - P_1 \pm F_s$	P ₃
CR104-A5	2	1	$P_0 = P_3 + P_5 - P_1 \pm F_s$	P ₆ , P ₄
CR104-A5	3	0	$P_0 = P_3 + P_5 + P_6 \pm F_s$	P ₄ , P ₁
CR104-A5	1	2	$P_0 = P_3 - P_1 - P_4 \pm F_s$	P ₅ , P ₆
CR104-A5	3	1	$P_0 = P_3 + P_5 + P_6 - P_1 \pm F_s$	P ₄

Table 1

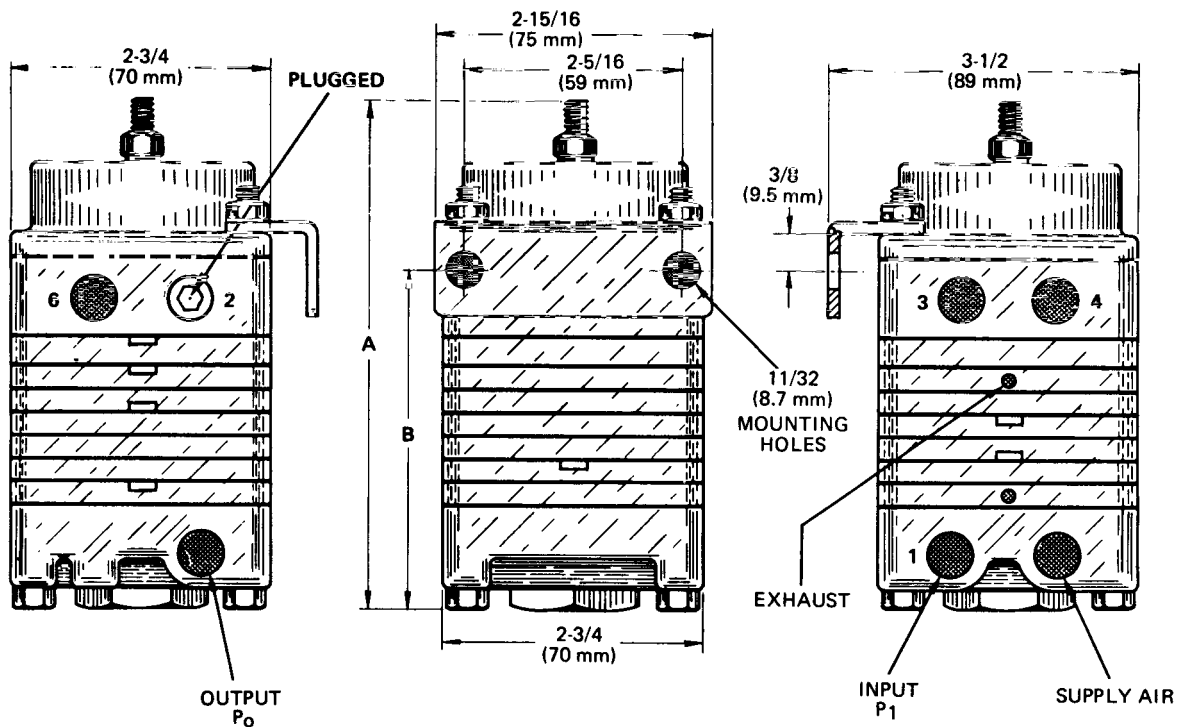

MODEL NO.	A	B
CR-104-A3	5" (127 mm)	3-1/4" (83 mm)
CR-104-A5	5-1/2" (140 mm)	3-3/4" (95 mm)

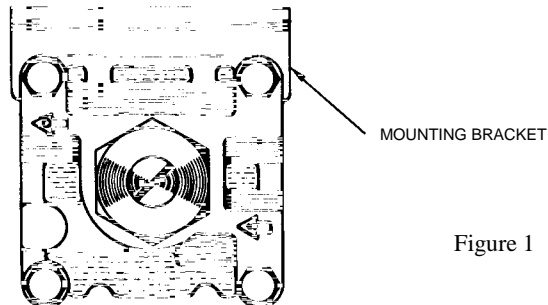

Figure 1

OPERATION (Refer to fig. 2)

As a result of the effective areas of the diaphragms: P₅ will create a downward force upon the center assembly, P₆ downward, P₄ upward, P₃ downward and P₁ upward. The downward motion of the center assembly will close the exhaust seat (B) of the valve and open the supply seat (A) of the valve, permitting supply air to flow into the output chamber. This pressure in the output chamber will increase until it balances the summation of forces upon the center assembly. As it approaches the balance pressure, it will move the center assembly upward, closing the supply seat (A) of the valve and throttling the flow of supply air. When the summation of input pressures and biasing spring force become less than the output pressure, the center assembly will rise, seating the supply seat (A) of the valve and moving away from the exhaust seat (B) of the valve. This exhausts the output pressure until it again balances the summation of forces.

In all adjustment, calibration or checking procedures, pressure gages of known accuracy level of 1/2% or better, or mercury manometers should be used.

A. BIAS (zero Shift) ADJUSTMENT

1. To raise "ZERO:"

With normal supply pressure applied and all input pressures at atmosphere (0 psig), turn the Bias Adjusting Screw clockwise until the output pressure (P₀) equals the desired value.

2. To lower "ZERO:"

If negative (-) bias or zero shift is required, proceed as follows: Apply an input pressure to PS slightly higher than the desired negative bias and leave the other inputs at zero psig. Adjust Bias Adjusting Screw counterclockwise until output pressure (P₀) is the difference between P₅ and the required negative bias.

Example: Desired bias = -5 psig (0.35 bar). Apply P₅ = 10 psig (0.70 bar). Adjust until P₀ = P₅ - F_s = 10 - 5 = 5 psig (0.35 bar).

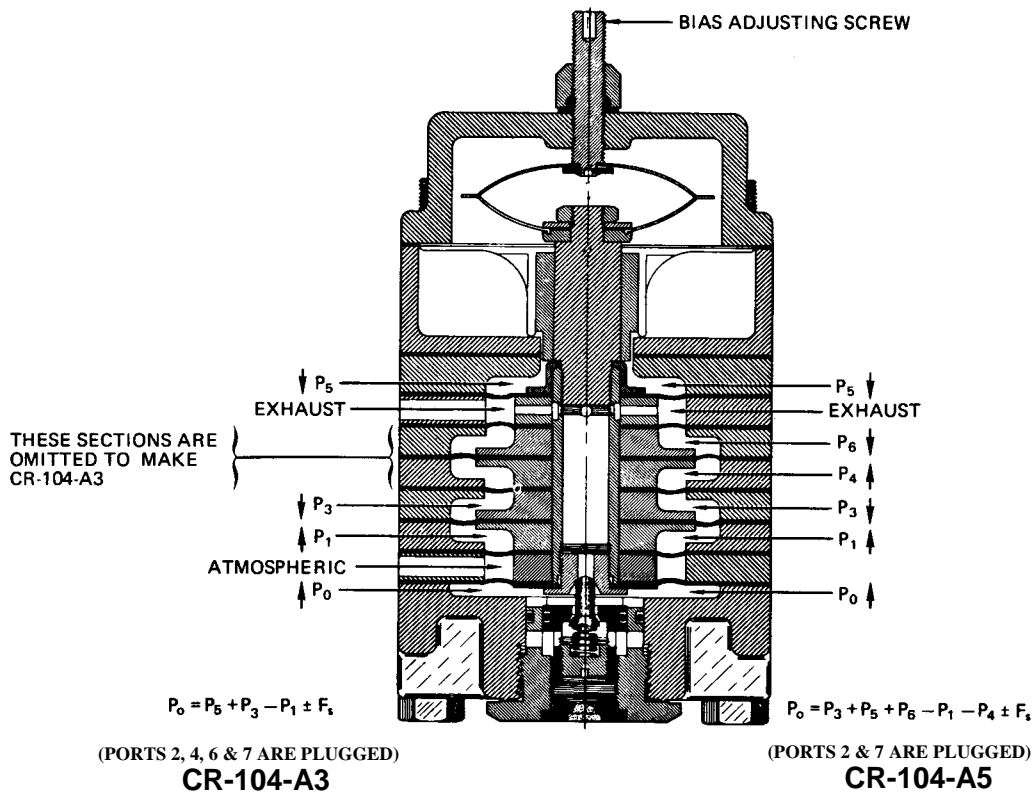

Figure 2

Schneider
 **Electric Systems USA, Inc**

1602 Mustang Dr
Maryville, TN 37801
Ph (865) 981-3100
FX (865) 981-3168

Q-3035 (2/19)

Printed in U.S.A.