

GENERAL DESCRIPTION

The 83454-Series Time Delay Relay provides either a time delay on application of pressure (on-delay) or on removal of pressure (off-delay) depending upon model used.

SPECIFICATIONS

Models Available:

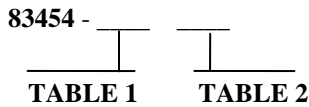

Table 1

Suffix	Description
E	Surface Mounted/ON Delay
F	Surface Mounted/OFF Delay
G	Panel Mounted/ON Delay
H	Panel Mounted/OFF Delay

Table 2

Suffix	Time Range
1	1.5 to 15 Seconds
2	1.0 to 300 Seconds
3	1.0 to 10 Minutes
4	6 to 60 Minutes

Control Pressure: .35 to 9.7 bar (5 to 140 psi). Timing action is independent of control pressure. The control medium itself does not pass through the timing mechanism.

Repeat Accuracy (The maximum deviation from the average of three consecutive time delays at any fixed temperature within the operating temperature range):

Suffix: ±1 - ±5%

Suffix: 2, 3, 4 - t 10%

Operating Temperature Range: -30 to 75° C (-20 to 165° F)

Storage Temperature Range: -55 to 75° C (-67 to 165° F)

Life Expectancy: 1 to 5 million operations (depending on operating pressure and frequency of operation)

Approximate Shipping Weight: 1.1 Kg (2-1/2 lb.)

Output Valve:

Pressure Range 700 mm Hg. vacuum to 20.7 bar (28" Hg. vacuum to 300 psig)

Capacity 5.2 dm³/s @ 5.5 bar with 6.4 mm orifice (11 SCFM @ 80 psig with 1/4" orifice)

Cv = .18

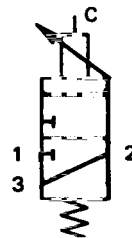
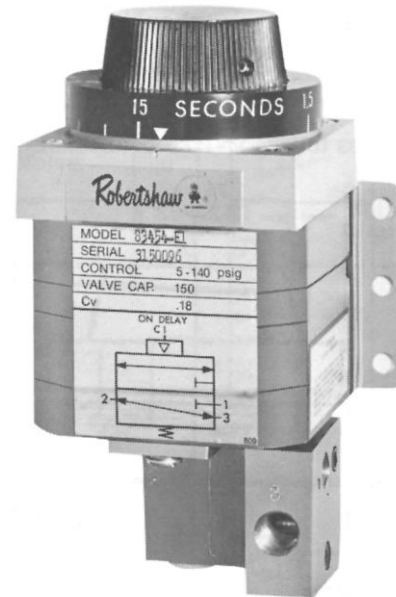

83454-E, G Series
(On Delay)

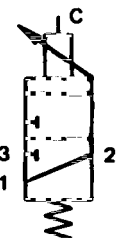

83454-F, H Series
(Off Delay)

JIC Symbol

Control Medium: Air, Natural Gas, Nitrogen, CO₂
Filtration (Minimum) 3 to 5 microns
Moisture (Pressure Dewpoint) 10° C (18° F)
 less than ambient temperature

NOTE: These are suggested minimums for control medium quality. For operation under more adverse conditions consult factory.

ORDERING INFORMATION

Specify:

Model Number and suffix.

INSTALLATION - See Figure 1

Mounting:

The 83454-Series Time Delay Relay may be mounted in any position. However, it should be noted that if the relay is mounted vertically, an approximate 5% change will be noted from the horizontal position. A particular dial setting may be incorrect by an amount equal to this 5% change. The relay should be mounted on the panel or other suitable surface to prevent excessive vibration.

Connections:

The relay has four 1/8"-NPTF connections. Typically,

actuating pressure is connected to port C and control pressure to port 1 or 3 with control output from port 2.

Tubing and fittings used to connect the unit must be free of chips, dirt, moisture or other foreign matter.

On fittings, it is recommended that a non-hardening, "anti-seize" type thread compound be applied to the threads in moderate amount. The first thread should then be wiped of any excess to avoid any compound from being deposited inside the relay. Thread sealing tape is not recommended.

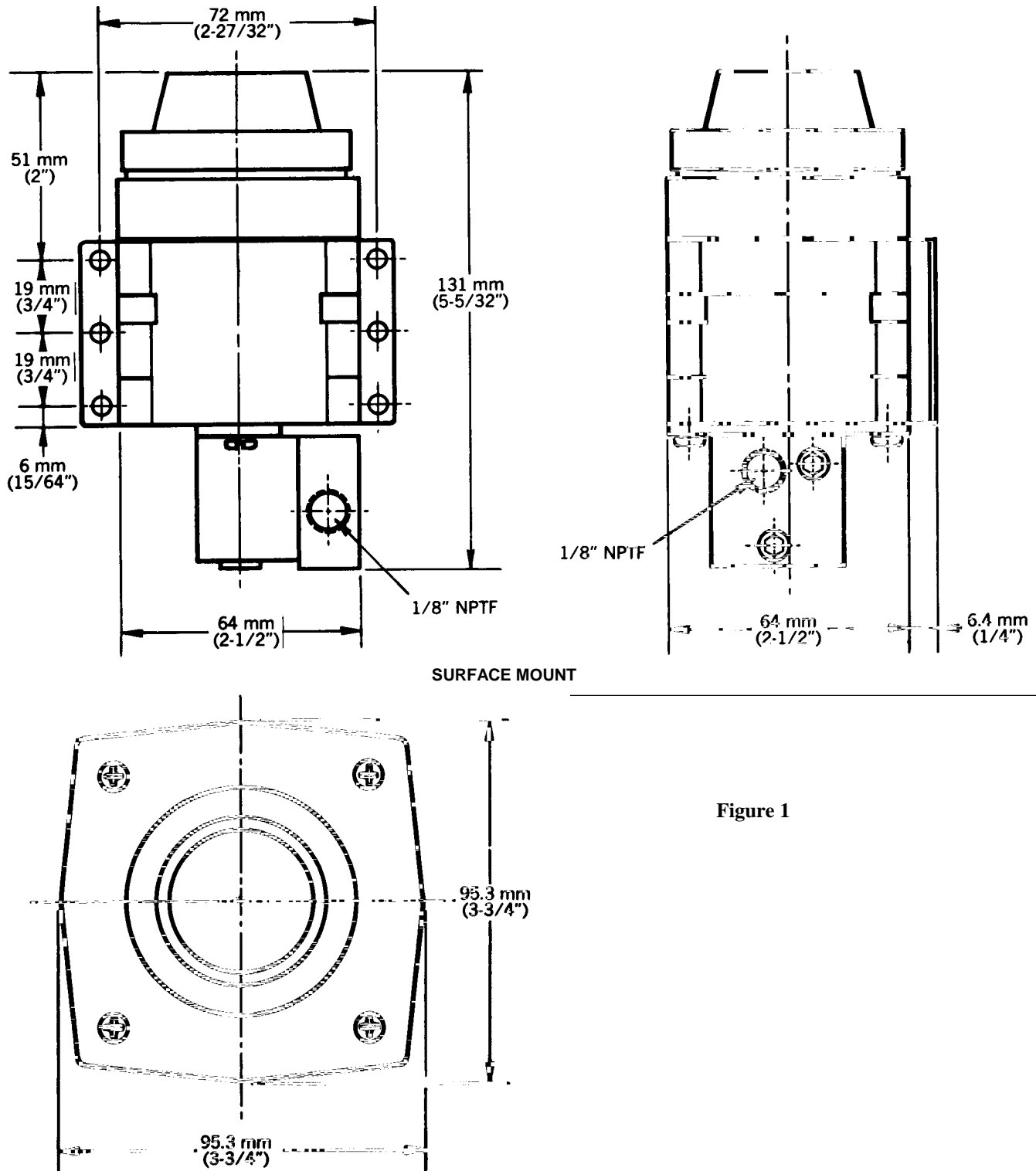

Figure 1

OPERATION

Two operating types are available, providing either delay on application of pressure to the motor diaphragm (On-Delay), or on removal of pressure (Off-Delay). Note that there is a transient bleed during transfer approximately equal to a .7 mm (.028") orifice.

On-Delay

Application of pressure at control port C actuates motor diaphragm, compressing recycle spring and allowing timing spring to exert pressure on timing diaphragm. This forces air through filter and dial-calibrated variable orifice. As air is exhausted from the timing chamber, spindle follows movement of the timing diaphragm. At end of the pre-set delay period, spindle actuates detent mechanism, causing snap-action transfer of the output valve. Removal of input pressure allows recycle spring to reset the motor diaphragm, causing the spindle to reset the output valve, and refill the timing chamber through the check valve.

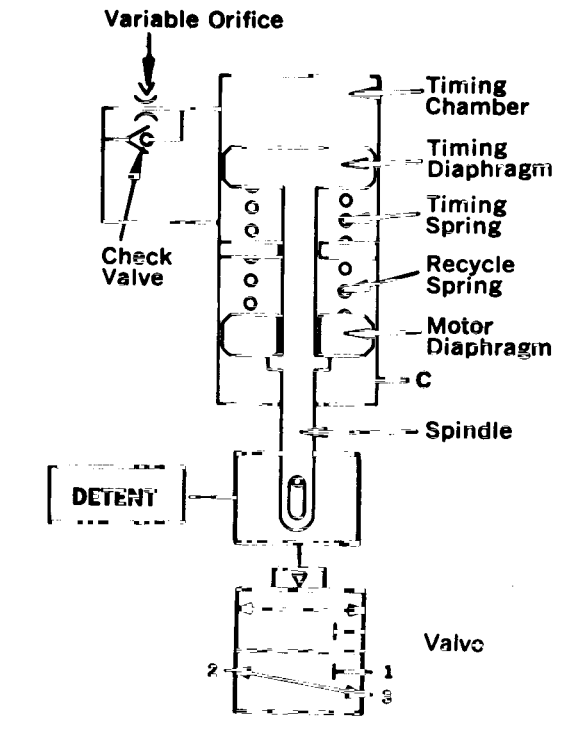

Figure 2a

Off-Delay

In this operating mode, application of input pressure at control port C actuates the motor diaphragm, instantly transferring the output valve and compressing the recycle spring. This simultaneously compresses the timing spring and fills the timing chamber with the ambient medium through the check valve. Upon removal of input pressure, recycle spring resets the motor diaphragm and permits the timing spring to exert pressure on timing diaphragm. Air is then forced through filter and variable orifice. When timing chamber is completely exhausted at end of delay period, spindle actuates detent mechanism, causing snap-action reset of the output valve.

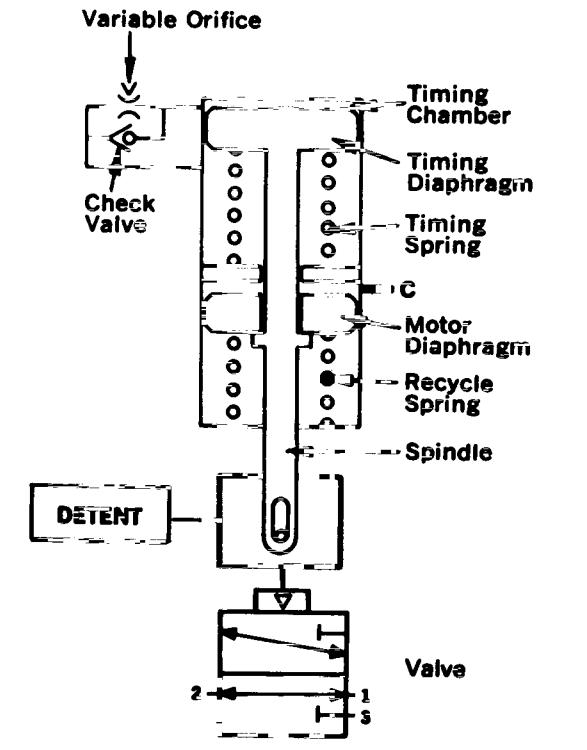

Figure 2b

MAINTENANCE - See Figure 3

If a time delay relay requires repair, either a new valve can be substituted on the relay or the entire unit replaced. Individual parts are not available.

Pistons and piston housings cannot be interchanged among valves. Only entire valve units can be substituted/interchanged/ replaced.

CAUTION: DO NOT APPLY OIL TO ANY PARTS.

Valve Cleaning:

Remove the two screws and lockwashers from the relay bottom. Slide valve to one side and remove from relay. Remove the two plate screws and plate. Remove the piston from the valve. Carefully push the magnet into the valve to force the piston housing from the valve. Remove the piston housing.

Carefully clean both the piston and the piston housing with tissue. After cleaning avoid handling these two parts with bare fingers. Reassemble, making sure the piston housing is correctly positioned in the valve.

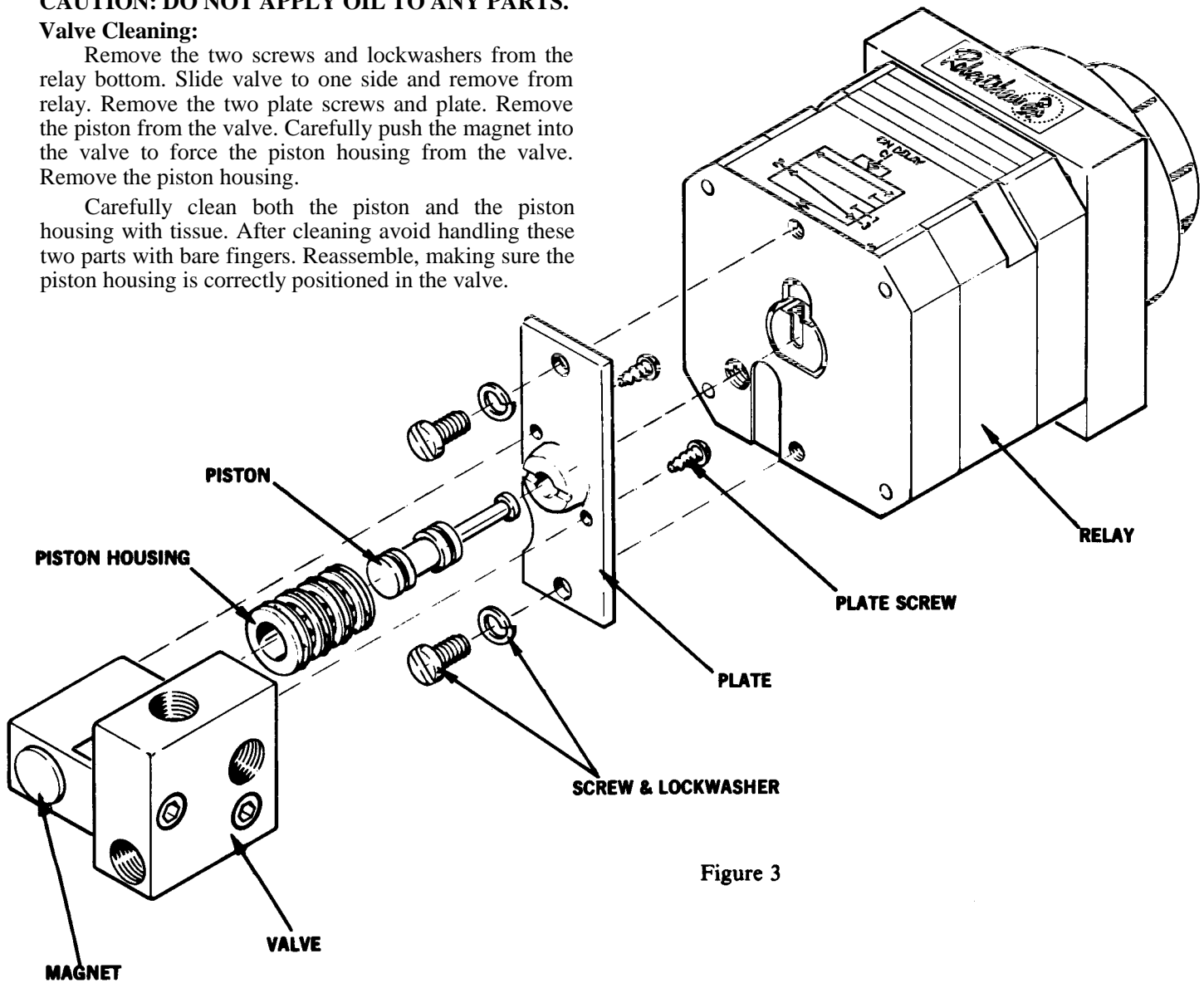

Figure 3

Schneider
Electric Systems USA, Inc

1602 Mustang Dr
Maryville, TN 37801
Ph (865) 981-3100
FX (865) 981-3168