

Receiver-Indicator Relay 82059 Series

GENERAL DESCRIPTION

The No. 82059 Series Receiver-Indicator Relay is a two-way, non-adjustable, snap-acting, two-position valve with a fluorescent indicator actuated by a pneumatic signal from a remotely located sensing device or transmitter.

The Receiver-Indicator Relay is used to indicate the safe or unsafe conditions of a measured variable and exhausts actuating pressure from a control system when the variable exceeds its setpoint.

SPECIFICATIONS

Construction:

Mounting Plate316 stainless steel.
Body Cast aluminum.
Springs Stainless steel.
Diaphragm Neoprene covered nylon.
Escutcheon Delrin.

Supply Pressure:20-50 psi (137.90-344.74kPa).

Operating Medium: Air, natural gas (dry, sweet) or an inert gas.

Pressure Required at Port to Transfer Relay:

Indicates green at 14-18 psi (96.53-124.11 kPa)
 Indicates red or red/white stripe at less than 8 psi (55.16 kPa)

Maximum Pressure: 60 psig (413.67 kPa)

CAUTION:

Do Not Exceed Maximum Pressure.

Mounting:Panel

Approximate Shipping Weight: 12 oz. (340.2 g)

Dimensions: See Figure 1.

Connections: 1/8" -27 NPT

Internal Orifice:028" diameter (.711 mm)

Panel Mounting Hole: 1 3/4" diameter (44.5 mm)

Minimum Recommended Centerline

Spacing: 3" (76.2 mm)

Panel Thickness:3/8" (9.53 mm) maximum

Models Available:

No. 82059-C1 - Green-Red indication

No. 82059-C2 - Green-red/white stripe indication

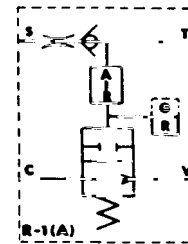

J. I. C. Symbol

ORDERING INFORMATION:

SPECIFY:

Model No.

INSTALLATION

A. GENERAL

Tube and fittings used to connect relay must be free of chips, dirt, moisture or other foreign matter. If thread compound or shellac is used, apply it only above second or third male thread in moderate amounts. Do not allow compound to be deposited inside relay.

For continuous, trouble-free operation, the air supply to the relay must be clean and dry.

B. MOUNTING

When installing the No. 82059 Series Receiver Indicator Relay, care must be taken to prevent foreign matter from entering ports.

For panel mounting, provide a 1 3/4" (44.5 mm) diameter hole. Remove escutcheon, insert relay through hole in panel, replace escutcheon and tighten by hand until escutcheon bottoms against the relay housing. To preserve appearance of escutcheon, do not use sharp-toothed tools, etc. Rotate mounting plate to a position where the screws are readily accessible. Tighten screws to lock relay in place.

C. CONNECTIONS

Port S is connected to a supply pressure regulated at 25 ± 5 psi (172.37 kPa \pm 34.48 kPa).

Port T is connected to a transmitter or sensing device. This transmitter or sensing device, receiving its supply from Port T, must be a two-way valve, or equivalent of sufficient size to vent the connecting tubing and be capable of dropping the pressure at Port T to 5 psi (34.48 kPa). It must also be capable of sealing off or blocking the Port T connection to the degree that is necessary to maintain 10 psi (131.0 kPa) at Port T.

Port C is normally connected to a final control element or to a device controlling a final control element, such as a combination relay, where a loss of pressure is necessary when an unsafe condition occurs. For connection to Port C, consult system schematic.

Port V is normally open when a system uses air as the operating medium. If an operating medium such as natural gas is used and a piped vent is required for safety purposes, Port V should be connected to a vent header through a short length of tubing-at least 1/4" (6.35 mm) diameter without any sharp bends.

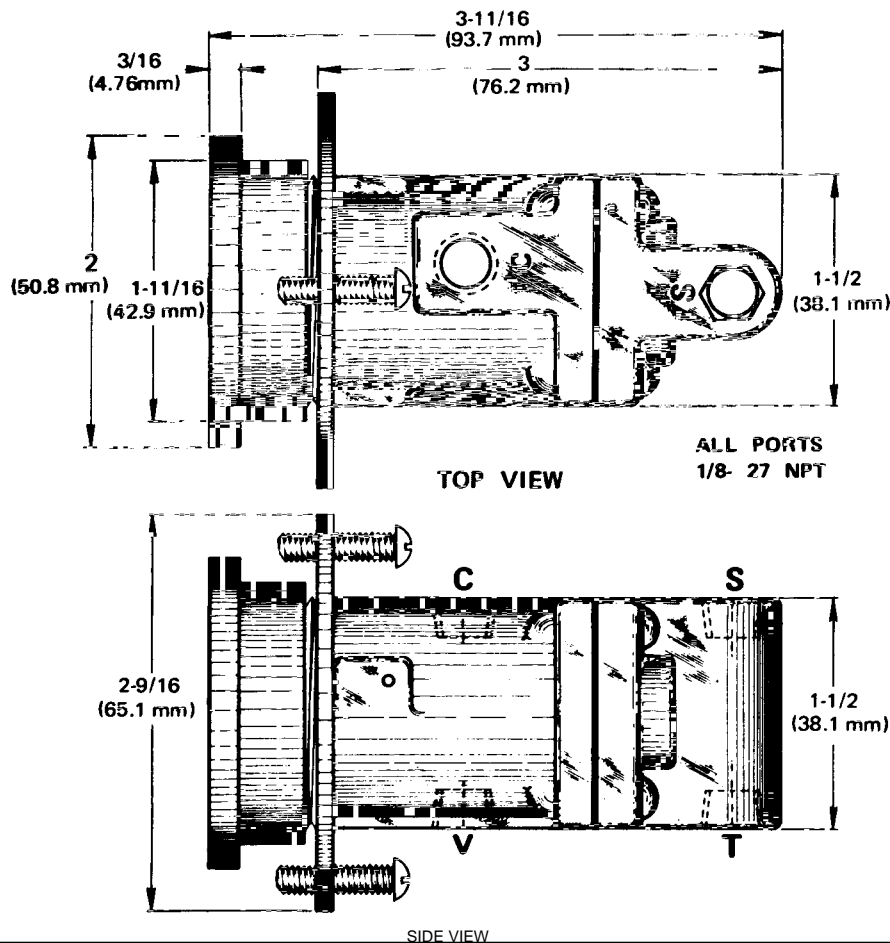
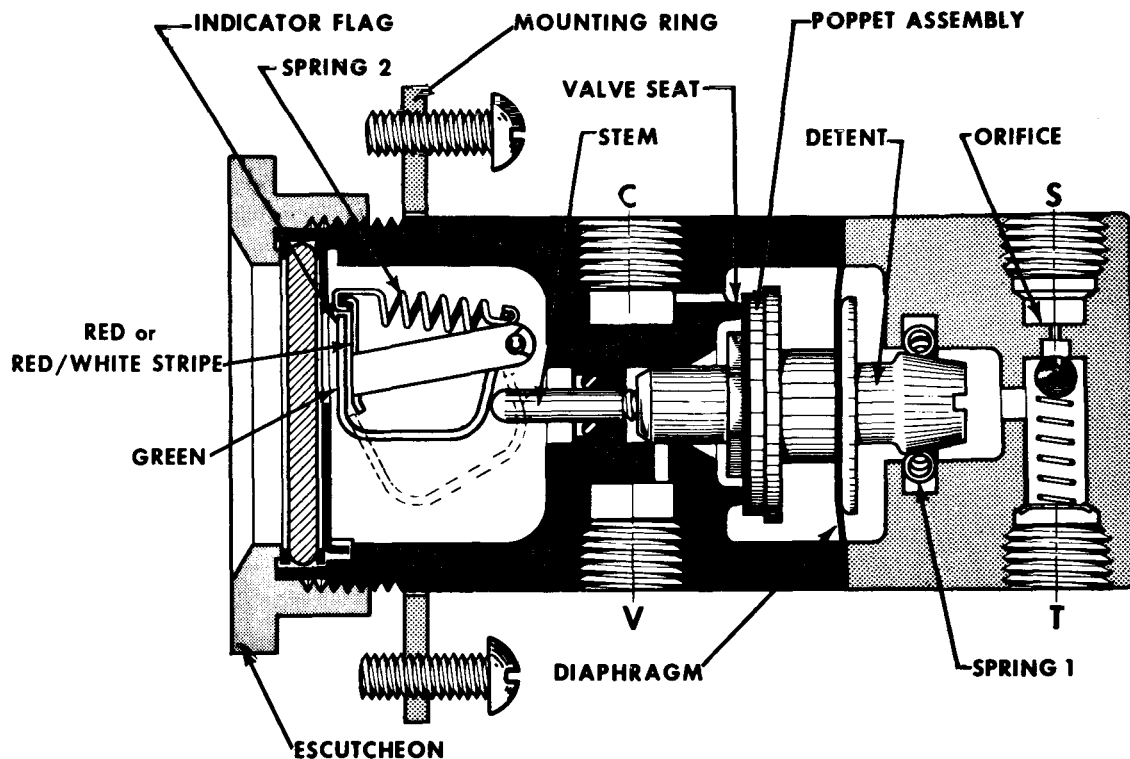

FIGURE 1



SHOWN INDICATING SAFE CONDITION OF VARIABLE

FIGURE 2

Supply pressure regulated at 25 ± 5 psig ($172.37 \text{ kPa} \pm 34.48 \text{ kPa}$) is connected at Port S. Port C is connected to the control circuit and Port T is connected to the sensing device or transmitter.

Operating medium introduced at Port S passes through the orifice to the bottom side of the diaphragm to Port T and to the connected sensing device or transmitter.

If the valve in the sensing device or transmitter connected at Port T is closed, pressure will build up on the bottom side of the diaphragm until sufficient force is developed to move the detent through spring 1, causing the stem to move against the load of spring 2. As the poppet assembly moves, the valve closes, blocking Port V; control pressure builds up and the indicator flag is rotated by the stem to show a green signal.

In the event the sensor connected at Port T senses a malfunction and vents, pressure is lost on the lower side

of the diaphragm. The control pressure on the top of the diaphragm then moves the detent through spring 1. The valve opens allowing Port C pressure to vent out Port V and the indicator flag to rotate showing a red or red/white stripe signal.

Loss of pressure at Port C can be utilized to affect a system shutdown. The indicator Flag retains its position at shutdown until the unsafe condition is corrected and pressure to the diaphragm is restored.

During normal operation the relay will always show a green indication except when sensing a malfunction from a transmitter or sensing device. In the event of a shutdown from another source, (either a malfunction from a sensor connected to another relay or normal stop) pressure is lost at Ports C and S. The force of spring 1 on the detent will hold the poppet assembly up and the indication will remain green.

MAINTENANCE WARNING:

Disassemble carefully-spring load forces present.

- A. The orifice may be inspected or cleaned by removing either the supply or transmitter lines.
- B. If relay does not function properly due to contamination by foreign matter, disassemble and clean all metal parts with cleaning fluid and dry thoroughly.
- C. After reassembly, check for external leakage. Tighten assembly screws as necessary. Gasket cement should not be used to seal leaks due to the possibility of plugging small passages and orifices or possible damage which might change the operating characteristics of the diaphragm.

CAUTION:

If cleaning is required, do not subject O-Ring, diaphragm or gaskets to cleaning fluid, acetone, or any halogenated hydrocarbon such as vapor degrease liquid, etc. Clean only with soft, dry cloth.

Upon reassembly, lubricate O-Ring with a silicone type lubricant. Do not permit lubricant to get on the poppet or valve seat.

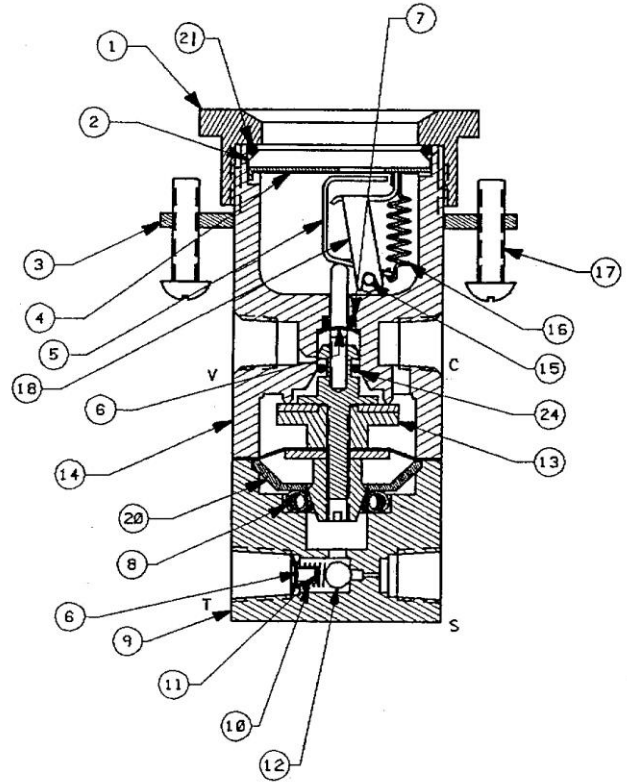

PARTS LIST

DET. NO.	NO. REQ'D	DESCRIPTION	DRAWING NO.
1	1	Escutcheon	30201-C1
2	1	Lens	30443-B1
3	1	Plate, Mounting	30444-B1
4	1	Window	30440-A1
5	1	Flag, Green	30439-A1
6	2	Retainer	36605-B1
7	1	O-Ring	36240-N1006
8	1	Spring	30445-A1
9	1	Cover	30330-B 1
10	1	Spring	32115-A1
11	1	Eyelet	36608-A2
12	1	Ball	23729
13	1	Assy. Poppet & Stem	82110-A1
14	1	Housing	30331-A2
15	1	Roll Pin	36606-A7
16	1	Spring	30441-A1
17	2	Screw	33716-A1710
18	1	Insert – For 82059-C1	30941-A1
		Insert – For 82059-C2	83136-B1
19	4	Screw	33713-J1310
20	1	Plate Detect	36352-A1
21	1	O-Ring	36240-N0122
22	4	Lockwasher	36600-L0609
24	1	O-Ring (not shown)	36240-N8

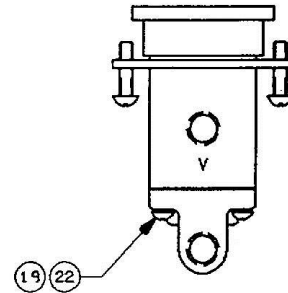

For Maintenance Kit containing O-rings, Poppet & Stem Assembly and Retainer needed to service one unit, order Repair Kit No. 82665-A4. Kit includes details 6 (1 piece), 7, 13 & 24.

Schneider
Electric Systems USA, Inc

1602 Mustang Dr
Maryville, TN 37801
Ph (865) 981-3100
FX (865) 981-3168