

FAIL-SAFE

INSTRUCTIONS
for
INSTALLATION and OPERATION
FAIL-SAFE
RT-1006 & RT-1007 Series

No. 1006-B1 Replaces No. 1006-A1 and No. 926

Temperature Regulator

Note to Installer. After installing the regulator, give this instruction folder to operating personnel or see that it is filed for future reference.

Robertshaw

Robertshaw

Industrial Products Division
1602 Mustang Drive
Maryville, Tennessee 37801
Phone: (865) 981-3100 Fax: (865) 981-3168

INSTRUCTION MANUAL NUMBER

P-2069

Rev. A

PRINCIPLE OF OPERATION

This regulator automatically controls flow of the medium passing through its valve by responding to temperature changes affecting the bulb. The bulb contains a thermo-sensitive liquid which vaporizes when heated. Vapor pressure thus generated in the bulb is transmitted through the capillary tube to the Sylphon® bellows which in turn positions valve poppet to control flow of the medium through the valve. Movement of the bellows is governed by a spring adjustment.

This regulator is active only within the temperature

range stamped on its nameplate and may be adjusted to operate at any point within that range. Action at this point is throttling and modulating.

"FAIL-SAFE" OPERATION – On loss of thermal charge, the load spring pushes the stem downward to close a direct-acting valve or to open a reverse-acting valve to prevent overheating with either valve. The stem of a three-way valve will also be pushed downward on thermal failure, and the result will be the same as if the bulb were sensing a high temperature.

VALVE INSTALLATION

Regulator valves are sized to the demand of heater or other unit to be controlled and are frequently smaller than supply line size.

When making the installation, do not remove valve from the regulator unless absolutely necessary.

The regulating valve should be installed as close as possible to the unit to be controlled and a pipe line strainer should be placed just ahead of the valve. Preferably, the regulator should be installed in the vertical position with the valve below the regulator frame. Regulators sizes 3" and larger should never be installed in horizontal position. Install valve so flow is in direction of arrow on valve body.

When controlling steam, provision should be made to drain coil or other condenser through a steam trap of adequate capacity and, if possible, with a good fall to the trap and no back pressure. Best control is obtained where coil or condenser is kept dry.

When controlling the flow of water used for cooling, the valve is usually on the supply end but may be on either end of the unit, depending on the nature of the installation, particularly with regard to backing-up full line pressure in the vessel. Fig. 26 shows a cooling application where the

regulator is installed in the return water line where control is applied to the combustion engine jacket cooling.

Cooling control valves are reverse-acting, opening with downward stroke on rise in temperature at the bulb, except on some applications where by-pass control only is utilized, requiring direct-acting valve.

CAUTION

If valve seat leakage can cause a problem or a hazard, the following should be taken into account. Maximum leakage of new valves: single-seated (types A, C,) - 0.05% of full open valve capacity; single-seated, balanced (type MA, MC, or MAS) - 0.01%; double-seated (types FA, etc.) - 0.5%. This leakage will usually increase somewhat as the valve seats wear in service.

TYPES WA, WC, WB and WD

Particular care must be taken when installing the three-way valve to make sure pipe connections are proper to obtain the control desired. The drawings below show the direction of flow through the valve when used for purposes stated. You can identify the side connections on the WA, WC and WB by the letters A, B and C stamped on the valve body. On the WD the letter E is used instead of A.

CONNECTIONS FOR TYPE "WB" OR "WD" VALVE

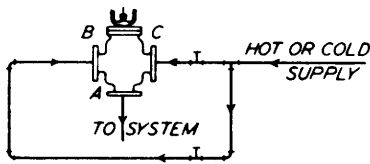

Figure 1

Showing how connections would be made where it is desired to shift from heating service to cooling service by manually opening and closing proper valves in the supply line.

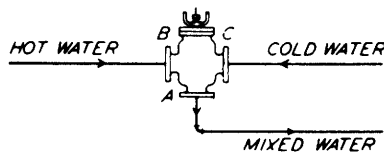

Figure 2

Illustrating a simple means for mixing hot and cold water where a rough mixing is suitable.

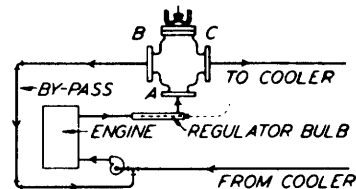

Figure 3

The drawing above illustrates the most widely used method of cooling water control for internal combustion engines.

CONNECTIONS FOR TYPE "WA" VALVE

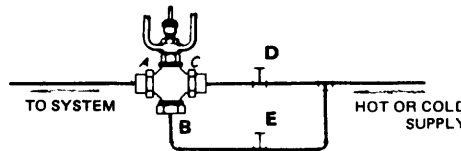

Figure 4

Showing how connections would be made where it is desired to shift from heating service to cooling service by manually opening and closing proper valves in the supply line. (For heating, close D and open E. For cooling, close E and open D.)

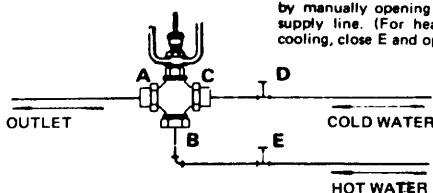

Figure 5

A suitable means for mixing hot and cold water where a rough mixing is suitable.

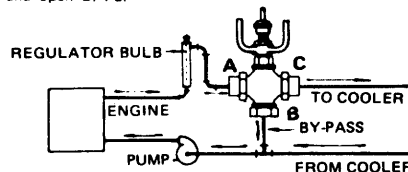

Figure 6

The most widely used method of cooling water control for diesel engines.

BULB INSTALLATION

IMPORTANT

Correct bulb location is the most important detail of regulator installation. Bulb should be installed at a point of true representative temperature and should be in good circulation. If a thermometer is used, it should be placed adjacent to the bulb.

NOTE: The elevation or depression of a regulator bulb with respect to the regulator sometimes has a marked effect on the range of the regulator. This is due to the effect of the column of liquid on a regulator working under "standard condition" (bulb warmer than tube and bellows).

The effect on the temperature range is as follows:

1. Range lowered if the bulb is above the regulator.
2. Range raised if the bulb is below the regulator.

NOTE: Units with cross-ambient ranges (those normally starting at or below 120° F.) must be installed with the regulator head and sensing bulb at the same elevation.

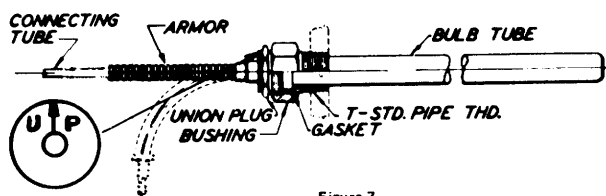

Figure 7
Standard type bulb for temperature control of liquids.

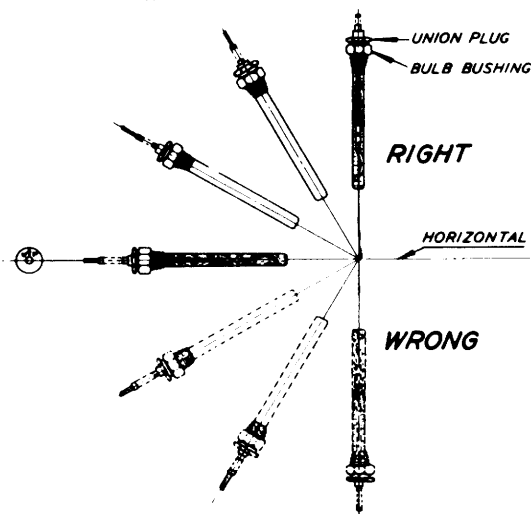

Figure 8
Showing RIGHT and WRONG way to install bulb. Positions from horizontal to vertical, inclusive, are correct if arrow on head plate points UP. For positions below horizontal, marked WRONG, a special bulb must be ordered.

LIQUID CONTROL – TYPE 12

The bulb for liquid control is of smooth tubular form with I.P.S. threaded bulb bushing as shown by Fig. 7. To install this bulb, loosen union plug until the bulb bushing turns freely on the bulb. Insert bulb and bushing into the selected opening and screw the bulb bushing up tight. Turn the bulb until arrow on head plate points UP. Tighten union plug. Bulb bushing can be removed from bulb by screwing union plug all the way out and in like manner bulb may be removed from installed position without disturbing bulb bushing.

The bulb may be installed horizontally or vertically or at any angle between these positions but in all cases, the arrow on the head plate must be uppermost. See "RIGHT,"

Fig. 8. Unless specifically ordered for such installation, the bulb should never be installed with the bushing end down or below the horizontal position. See "WRONG."

Bulb in gravity circulation heaters should be above heating surface but not closer than 4" at any point. See Fig. 23.

For instantaneous heaters, bulb should be in the heater outlet line and as close as possible to the point where this line connects to the heater. See Fig. 24. For such installation, the pipe line should be twice the bulb diameter to obtain free flow around the bulb. See Fig. 9.

A bulb should never be installed where cold inlet water will flow directly on it or where it will be otherwise affected by false temperatures. See Fig. 23.

LIQUID CONTROL – TYPE 6

This is a plain type bulb not provided with a bushing or other means for its support in a vessel in which it is to be placed.

Bulb should be installed vertically below surface of the liquid.

Bulb should be located away from work area inside tank and should be supported in position by suitable means.

NEVER lay bulb on bottom of tank. However, bulb may be installed horizontally if it is securely mounted to side of tank and the word "TOP" on tube end of bulb is up.

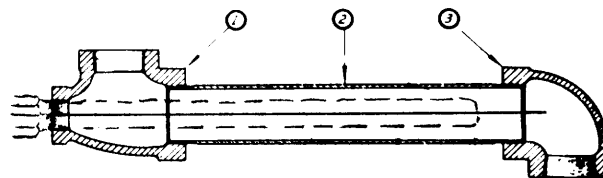

Figure 9
The drawing above shows how the regulator bulb may be installed in the pipe line. The pipe size (detail 2) should be at least twice the bulb diameter so that free flow can be had around the bulb. Where the pipe line is not of sufficient diameter to accommodate the bulb, an enlarged section with proper fittings could be provided.

AIR CONTROL – TYPE 54-A PLAIN 54-J BUSHED and 54-K FLANGED

The bulb is an externally finned type for greater sensitivity. Bulb should be installed at right angle to the air movement and at a location where average temperatures are encountered. See Figs. 27, 28 and 30. Preferably, the bulb should be installed horizontally, but it may be installed vertically or at any angle between these positions providing the tube end is uppermost—never install bulb with tube end down unless specifically ordered for such installation. See Fig. 8. Bulbs have a plate attached (See Fig. 7) to the tube end indicating that the bulb should be installed with the arrow pointing upward when the bulb is installed in any position "RIGHT."

SEPARABLE WELL – TYPE GA

The thermometer well or socket type bushing serves as a protection to the bulb and allows the bulb to be removed without disturbing the contents of the vessel.

To install, insert well into the selected opening and tighten. Insert bulb in socket and tighten union plug (Fig. 7). Be sure arrow is pointing up as plug is tightened.

CONNECTING TUBING

The flexible tubing connecting the bulb and valve must not be cut, kinked, mashed or unduly twisted. It may be bent on a 3½" radius or larger. Tubing may be fastened in a permanent fashion to a rigid location but not fastened to

steam pipes or other locations where subject to extreme temperatures. A small loop of tubing next to the regulator head is recommended to absorb vibrations occurring in pipe line.

TEMPERATURE ADJUSTMENT

This regulator can be set to control at any temperature within the limits of the temperature range stamped on its nameplate.

After placing the regulator in service, allow about 30 minutes to reach stable operation, then observe temperature. If not correct, change the temperature setting in manner directed below.

(NOTE: Following adjustment is opposite to that for most regulators.)

To RAISE temperature setting, turn adjustment wheel to LEFT (see arrow "A") (Fig. 10).

To LOWER temperature setting, turn adjustment wheel to RIGHT (see arrow "B") (Fig. 10).

NOTE: A locknut "G" with set screw is located under the adjustment wheel "F," Figure 10, which should be loosened to allow adjustment and tightened to maintain final adjustment.

Make new settings as necessary until desired temperature is obtained but allow about 30 minutes between changes.

The regulator has a scale plate to indicate the position of the adjustment. This feature is helpful in resetting the adjustment when frequent changes are necessary. Scale graduations are not in degrees of temperature.

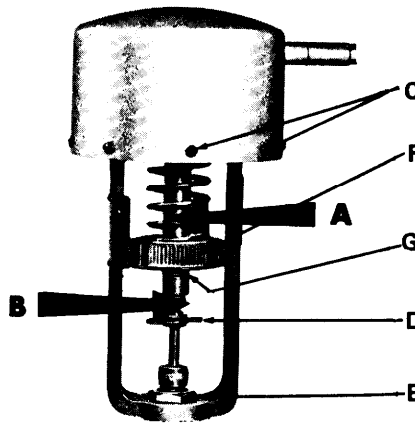

Figure 10

MAINTENANCE

This regulator, if properly installed and used, should require very little attention or maintenance; however, every piece of mechanical equipment deserves some care.

PACKING

Valve stem packing nut should be kept FINGER-TIGHT. If valve stem packing must be replaced, follow steps below. (see Figs. 11 and 12.)

1. Removal of lock pin (D) – (See Fig. 10):

a. Direct-acting valves as used on heating applications:

In order to easily remove lock pin (D), it may be necessary to remove the thermal bulb from the process and cool the bulb by means of a water bath so that the valve plug is lifted from the seat approximately 1/8".

b. Reverse-acting valves as used on cooling applications:

In order to easily remove lock pin (D), it may be necessary to remove the thermal bulb from the process and heat the bulb by means of a steam jet or water bath so that the valve plug is moved from its seat approximately 1/8".

CAUTION: Do not rotate the frame with the valve pressed firmly on-seat as such rotation may cause galling or scoring of the sealing surfaces.

2. Remove locknut (E) and separate control from valve.
3. Remove packing nut and packing gland.
4. Remove bonnet from valve.
5. Remove packing spring plate and spring.
6. Clean out packing box with a clean rag or soft paper.
7. Wipe off stem with clean rag or fine steel wool. DO NOT attempt to polish. If stem is scratched or nicked around packing area, it should be replaced.
8. Replace bonnet or valve.
9. Carefully place new packing in packing box. If Chevron or U-cup packing is not available, in an emergency, repack with a good grade of graphited string packing. Put a small amount of good packing lubricant in the stuffing box while repacking. This packing, however, should be replaced with Teflon* Chevron or U-cup packing as soon as possible.
10. Replace packing gland.
11. Replace packing nut and tighten.
12. Connect valve to control and tighten locknut.
13. Before inserting lock pin (D), use the same procedures as given under 1. above to position actuator stem so that the lock pin may be easily inserted.

*Registered tradename of DuPont Company

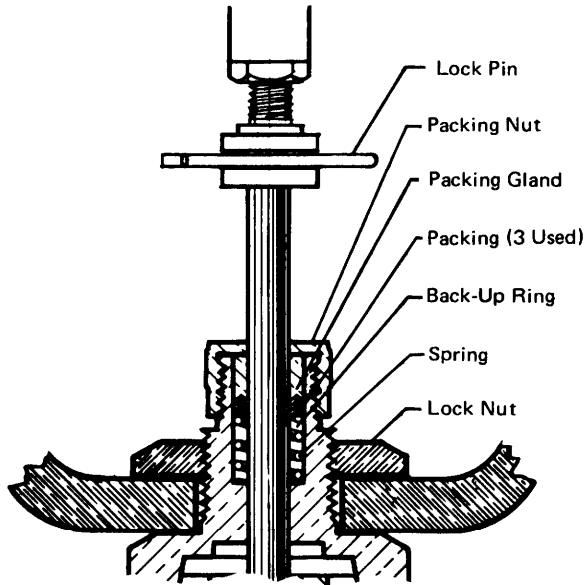

Packing used for steam or heating service (direct-acting valve)

Figure 11

THERMOSTATIC ELEMENT

The thermostatic element consists of bulb, flexible tubing and bellows assembly. This unit contains the thermostatic charge. In event this charge is lost as a result of damage or otherwise, thermostatic unit must be purchased and installed as a complete unit. It is not repairable in the field.

CAUTION – Never remove or install thermostatic unit when temperature of bulb is above lowest temperature of the range stated on nameplate.

To remove thermostatic element, follow steps listed below.

1. Remove regulator bulb from its location by screwing union plug (Fig. 7) all the way out.
2. If room temperature is more than 10° above the highest temperature of range stated on nameplate, place bulb in container of cool water, ice, or dry ice (only for very low ranges).
3. Loosen set screw and the locknut "G" located under the adjustment wheel "F" (Fig. 10).
4. Turn adjusting wheel to LEFT (see Arrow "A", Fig. 10) until adjusting wheel is all the way off the threaded adjusting stem.
5. Remove screws "C" (Fig. 10) and lift off element.
6. To install thermostatic element, revise the above operations.

REMOVING OR INSTALLING VALVE

1. Remove lock pin (D) (Fig. 10). (Do not disturb lock nut connecting regulator stem to connector.)
2. Remove lock nut (E) (Fig. 10) and lift regulator frame off valve body.
3. Remove valve from line.
4. To install valve, reverse the above operations.

REFACING VALVE SEAT

Under certain conditions, the valve seat may be lapped with the valve poppet. However, this should be done only by an experienced person. If the valve poppet or insert is badly scored, it should be replaced.

If valve is to be lapped, remove regulator from valve (see REMOVING VALVE), remove bonnet, and place a small amount of (extremely fine) grinding compound on the valve insert face. In lapping, every effort should be made to avoid scoring or grooving the contact faces. Wipe poppet and insert thoroughly with a clean rag after each operation.

Use light pressure in lapping even to the extent of holding up part of the weight of the poppet as it is rotated. Frequently lift off poppet to check surface.

Heavy pressures cause the grains to become embedded in the material and will produce deep grooves or scores.

When seating face of poppet is smooth, grooves or lapping scores in seating face of insert, if not too deep, do not particularly harm or in some cases seem to assist in getting a quick seat. Wipe away all compound from the valve poppet and inserts.

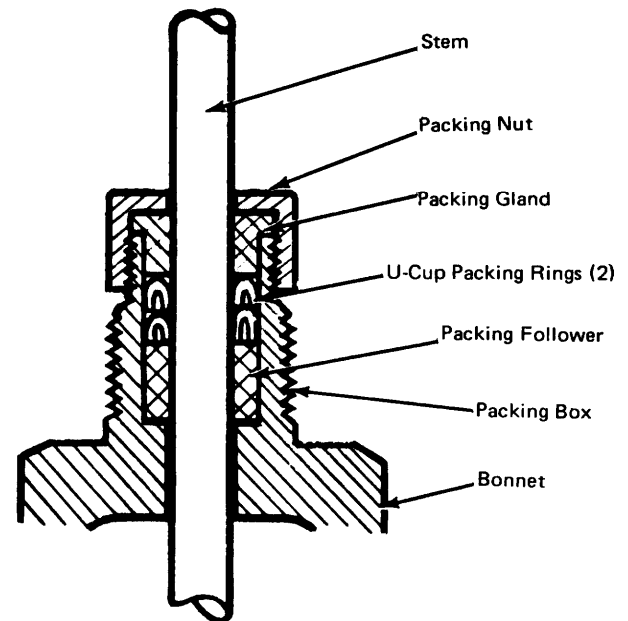

Packing used for cooling service (reverse-acting Valve).

Figure 12

TROUBLE SHOOTING

This regulator is supplied to operate within the temperature range stated on the nameplate. If the regulator does not function properly immediately after completing the installation, and you are unable to correct the trouble, write to the factory, or contact the nearest field office, and outline your difficulties.

If the regulator has been operating satisfactorily for some time and trouble develops, the following information may be of assistance.

HEATING

If no heat or inadequate heat is obtained with highest temperature setting, make sure that hand valves ahead of the regulating valve are open and that steam of sufficient pressure is passing to the regulator valve. Blow, or otherwise clean the line strainers. Clean all traps and see that they are in working order. If the return line to the trap is cool, the steam coils may be clogged.

In all cases, the packing nut should be only finger-tight. Valve stem must be free to move up and down without undue friction.

The usual cause for overheating is the collection of scale or other foreign matter on the valve seat or seats. Such matter may hold the poppet off seat and in time cause the seat or poppet to become scored. To inspect seats and poppet, remove valve bonnet in same manner as directed under heading "REFACING VALVE SEAT". Slightly scored seats or poppets may be reground. Valve repair kits and/or replacement valves are available from the factory.

Overheating may be caused by failure of thermostatic unit. See "THERMOSTATIC ELEMENT" below.

CAUTION:

If valve seat leakage can cause a problem or a hazard, the following should be taken into account. Maximum leakage of new valves: single-seated (types A, C), - 0.05% of full open valve capacity; single-seated, balanced (type MA, MC, or MAS) - 0.01%; double-seated (types FA, etc.) - 0.5%. This leakage will usually increase somewhat as the valve seats wear in service.

Damage to or failure of the thermal element with loss of charge will ordinarily result in the regulator going to the "cold" position. The valve stem moves "up" (toward the bellows) - thus a "direct-acting" valve will fully open and a "reverse-acting" valve will close.

COOLING

If the regulator is used for cooling purposes, such as controlling circulation of water or brine, make sure that proper circulation is possible through the cooling circuit if sufficient cooling is not obtained. All lines, strainers, hand valves and passages in heat exchanger should be open. If over-cooling is experienced, scale or other foreign matter may be present on the valve seat or seats, preventing poppet from seating and thus allowing excessive flow of the cooling medium, or the supply pressure may be excessive. To inspect poppet and seats, disassemble valve as directed under heading "REFACING VALVE SEAT."

In all cases, the packing gland nut should be only finger-tight. Valve stem must be free to move up and down without undue friction.

Regulators controlling circulation of brine should be inspected for frost on valve stem or frozen stem in packing gland.

THERMOSTATIC ELEMENT

Failure of the thermostatic element is indicated by failure of the regulator to respond to temperature changes affecting the bulb. With such failure the valve stem would be down. (Refer to "PRINCIPLES OF OPERATION," page 2.)

To test thermostatic element, remove bulb from its location and observe valve stroke by placing the bulb in a suitable container where it can be quickly heated with hot water or steam and cooled with cold water or crushed ice. If thermostat does not readily respond, it has lost its thermostatic charge and a new element must be installed, or the damaged one repaired.

NOTE - When writing to the factory be sure to give serial number and other information appearing on the nameplate.

Dimensions and Shipping Weights

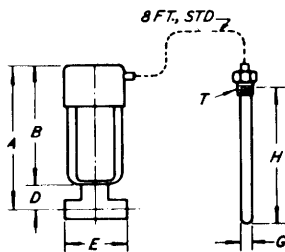

Regulator No.	RT-1006-B1					RT-1007-A1					
	1/4	3/8	1/2	3/4	1	1 1/4	1 1/2	2	2 1/2	3	4
Valve Size, Inches.....											
Direct-Acting Valve, Type.....	C	C	A	MA	MA	MA	MA	FA	FA	FA	FA
Ship. Wt., Lbs.....	26	26	27	29	32	37	43	48	100	130	160
A.....	12 9/16	12 9/16	12 9/16	14 3/16	14 7/16	15 3/16	16 5/16	17 1/2	16 5/16	16 5/16	18
B.....	11	11	11	11	11	12 3/16	12 3/16	12 3/16	12 3/16	12 3/16	12 3/16
D.....	1 9/16	1 9/16	1 9/16	3 7/16	3 7/16	3 3/8	4 1/8	4 3/8	4 3/8	4 3/8	5 3/8
E.....	2 7/8	2 7/8	4 3/8	6 1/8	7 1/8	7 1/2	8 1/2	7	7 3/8	8 3/8	10 1/4
Standard bulb for temperature ranges beginning at 120°F. or above											
G.....	1	1	1	1	1	1 1/4	1 1/4	1 1/4	1 1/4	1 1/4	1 1/4
H.....	11	11	11	11	14	18	18	24	18	18	24
T*.....	1	1	1	1	1	1 1/4	1 1/4	1 1/4	1 1/4	1 1/4	1 1/4
** Standard bulb for temperature ranges beginning below 120°F.											
G.....	1 1/4	1 1/4	1 1/4	1 1/4	1 1/4	1 1/2	1 1/2	1 1/2	1 1/2	1 1/2	1 1/2
H.....	18	18	18	18	20	28	28	32	28	28	32
T*.....	1 1/4	1 1/4	1 1/4	1 1/4	1 1/4	1 1/2	1 1/2	1 1/2	1 1/2	1 1/2	1 1/2

* Standard pipe thread
 ** Bulb sizes for ranges beginning below 120°F. are necessary to provide "cross-ambient" charge. This assures operation with ambient temperatures either above or below the control setting. Under some conditions, smaller bulbs may be used with lower ranges. If the larger bulb cannot be used, consult the factory or your nearest Fulton Syphon representative.

VALVE TYPES

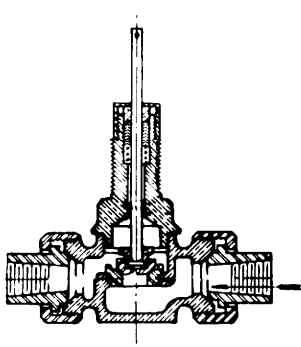

Figure 13
Type "A" Valve
Direct-Acting

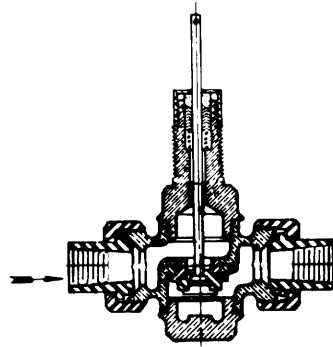

Figure 14
Type "A" Valve
Reverse-Acting

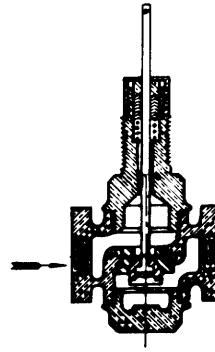

Figure 15
Type "C" Valve
Direct-Acting

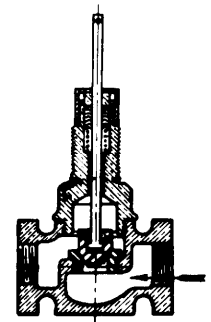

Figure 16
Type "C" Valve
Reverse-Acting

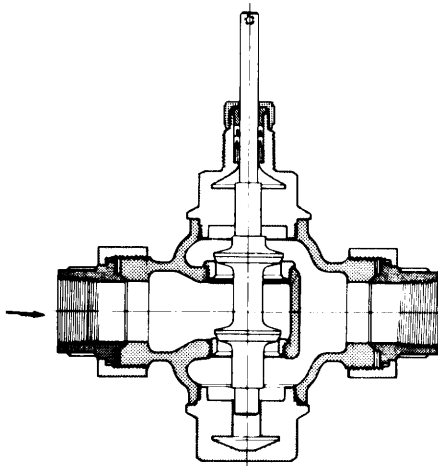

Figure 17
Type "FA" Valve
Direct-Acting

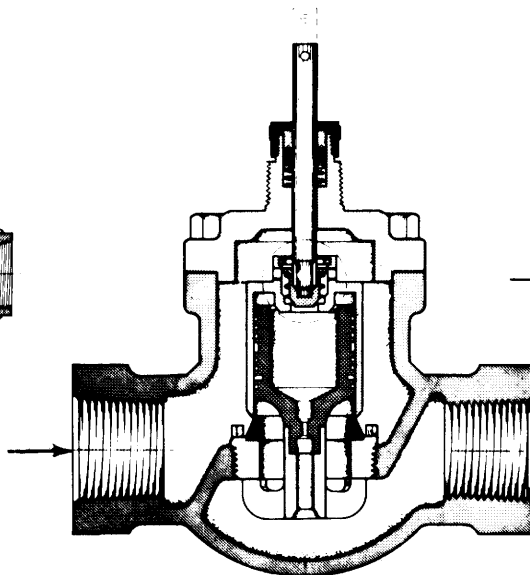

Figure 19
Type "MA" Valve
Size $\frac{3}{4}$ to $1\frac{1}{2}$ Screwed Ends
Size 2 Flanged Ends

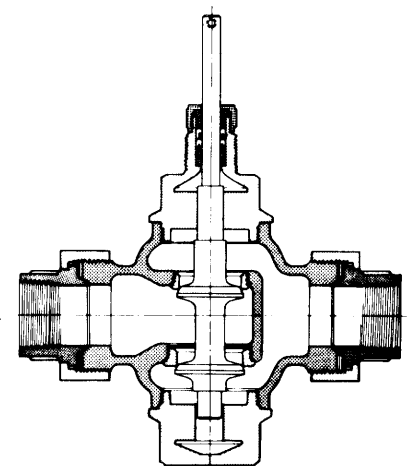

Figure 18
Type "FA" Valve
Reverse-Acting

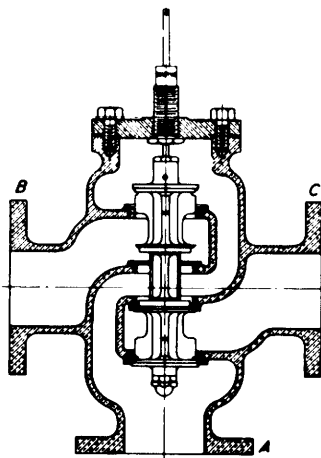

Figure 21
Type "WB" Valve

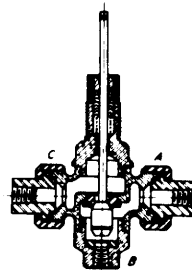

Figure 20
Type "WA" Valve

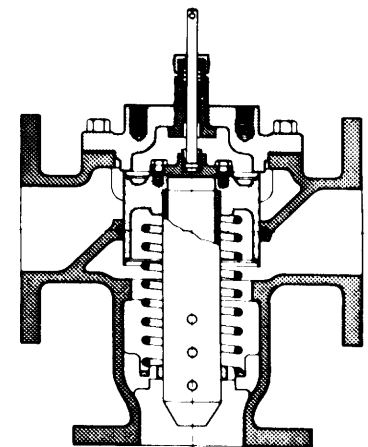
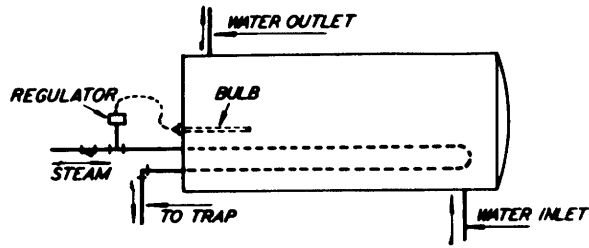

Figure 22
Type "WD" Valve

TYPICAL INSTALLATIONS



CLOSED TANK OR STORAGE WATER HEATER

Figure 23

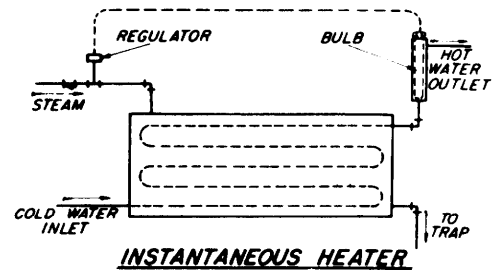

INSTANTANEOUS HEATER

Figure 24

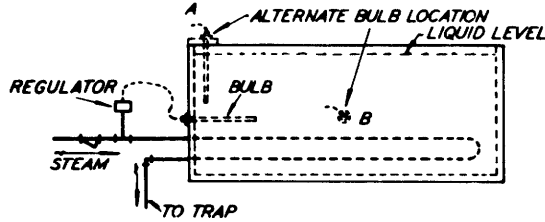

OPEN TYPE TANK

Figure 25

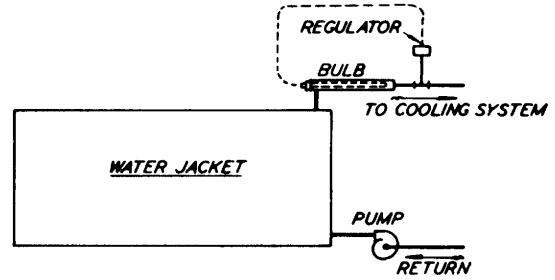

ENGINE JACKET COOLING

Figure 26

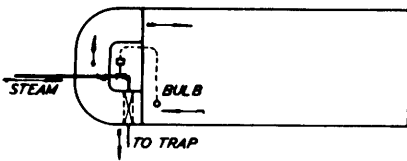

CIRCULATING DRYER

Figure 27

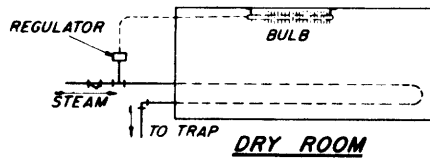
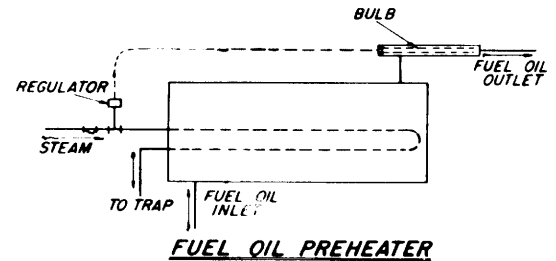
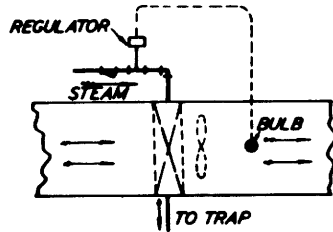

Figure 28



FUEL OIL PREHEATER

Figure 29



HEATING DUCT

Figure 30

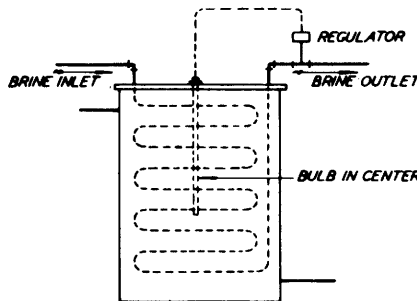

LIQUID COOLER

Figure 31

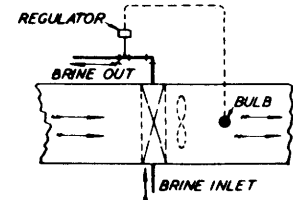

COOLING DUCT

Figure 32

Robertshaw

Industrial Products Division

U.S.A and Canada
 Robertshaw Industrial Products Division
 1602 Mustang Drive
 Maryville, Tennessee 37801
 Telephone: (865) 981-3100 Fax: (865) 981-3168
<http://www.robertshaw.thomasregister.com>
<http://www.robertshawindustrial.com>

Exports
 Invensys Appliance Controls
 2809 Emerywood Parkway
 P.O. Box 26544
 Richmond, Virginia 23261-6544
 Telephone: (804) 756-6500 Fax: (804) 756-6561