



**Industrial Products Division**

**U.S.A. and Canada**

Robertshaw Industrial Products Division  
 1602 Mustang Drive  
 Maryville, Tennessee 37801  
 Telephone: (865) 981-3100  
 Fax: (865) 981-3168

**Exports**

Invensys Appliance Controls  
 1701 Byrd Avenue  
 P.O. Box 26544  
 Richmond, Virginia 23261-6544  
 Telephone: (804)756-6500  
 Fax: (804) 756-6561

**FEATURES:**

- Corrosion resistant
- ESD protection
- Reverse wiring protection
- Overload protection
- Hermetic
- No trim pots

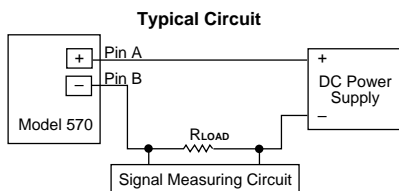
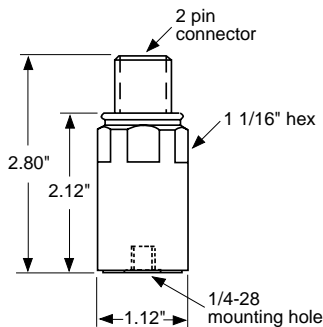

**Model 570B Series  
Two-wire Vibration Sensor**

**SPECIFICATIONS**

**DYNAMIC**

Output (±5% of Full Scale) .....	4-20 mA DC
Vibration Range .....	see table below
Frequency Response:	
-3 dB .....	see table below
Repeatability .....	±2%
Resonant Frequency, mounted, nominal .....	see table below
Transverse Sensitivity, max. ....	5%

**ELECTRICAL**

Power Requirements (Two wire loop power):	
voltage source .....	10 VDC - 30 VDC
Loop Resistance <sup>1</sup> at 24 VDC, maximum .....	700Ω
Turn on Time .....	<30 seconds
Grounding .....	Case isolated, internally shielded

**ENVIRONMENTAL**

Temperature Range .....	-40 to 85°C
Vibration Limit .....	250 g peak
Shock Limit .....	2,500 g peak
Electromagnetic Sensitivity, equiv. g .....	10 µg/gauss
Sealing .....	hermetic, NEMA 4X, IP68

**PHYSICAL**

Weight .....	162 grams
Sensing Element Design .....	PZT ceramic / shear
Case Material .....	316L stainless steel
Mounting .....	1/4 - 28 tapped hole
Output Connector .....	2-pin, MIL-C-5015 style
Pin A .....	plus (+) White
Pin B .....	minus (-) Black
Cabling <sup>2</sup> .....	Two conductor shielded (See Table 1 on back)
Torque Limit .....	30 in lbs. max
Warranty .....	1 year

**NOTES:** <sup>1</sup> Maximum loop resistance can be calculated by:

$$R_L \text{ (max)} = \frac{V_{\text{power}} - 10 \text{ V}}{20 \text{ mA}}$$

Loop resistance is the sum of wiring resistance and the load resistor.

<sup>2</sup> Cable resistance equals 40 ohms, total per 1000 ft.

Typical	
Power Source Voltage	R <sub>L</sub> max
20	500
24	700
26	800

**ACCESSORIES SUPPLIED:** 1/4-28 mounting stud.



Model	Mode	Range	Frequency Response	Resonant Frequency
570B-A	acceleration	0 - 5 g peak	2 Hz - 2 kHz	28 kHz
570B-B	acceleration	0 - 10 g peak	2 Hz - 2 kHz	28 kHz
570B-C	acceleration	0 - 20 g peak	2 Hz - 2 kHz	28 kHz
570B-D	velocity	0 - 0.5 IPS peak	2 Hz - 2 kHz	28 kHz
570B-E	velocity	0 - 1 IPS peak	2 Hz - 2 kHz	28 kHz
570B-F	velocity	0 - 2 IPS peak	2 Hz - 2 kHz	28 kHz

**TABLE**

## Mounting Instructions

The mounting point on the structure should be faced to a diameter of 1.25 inches. For measurements involving frequencies above 1 kHz, the surface should be flat within 1 mil and have surface texture no greater than 32 microinches.

The tapped hole must be perpendicular to the mounting surface and at least two threads deeper than the stud. This will prevent a gap between the sensor and the mounting surface—producing optimum frequency response. (see Figure 1).

Proper screw torque on the mounting stud is also required. Under-torquing the sensor reduces the stiffness of the coupling. Over-torquing can cause permanent damage to the sensor. It is recommended that 1/4-28 stud be torqued to a maximum value of 30 inch-pounds.

Before stud mounting the sensor, a coupling fluid should be applied to the mating surfaces. The coupling fluid protects the mounting surface and optimizes the frequency response by increasing the coupling stiffness. Suggested coupling fluids are machine oil or vacuum grease. It is recommended that a thread adhesive such as Loctite 222 be used.

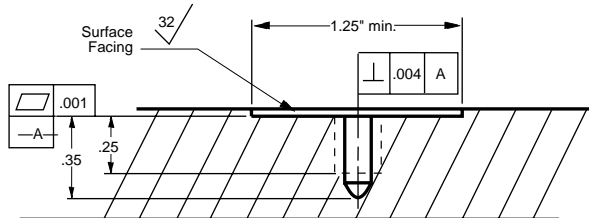

Figure 1: Stud Mounting: Surface Preparation

## Cable Routing and Electromagnetic Interference

Walkie-talkies, power lines, or even electrical sparks may cause signal interference. The following guidelines will eliminate many measurement errors due to electromagnetic radiation and electrostatic discharge (ESD).

Assure that high quality, well shielded cables are used. If cable splices are made, complete shielding must be maintained.

Proper cable routing is imperative. Never run sensor cable alongside AC power lines; cables must cross AC power lines at right angles. Where possible, provide a separate grounded conduit to enclose the sensor cable. In addition, route the cable away from radio transmission equipment, motors/generators, and transformers. Finally, avoid routing the cable through areas prone to ESD. Even though Robertshaw sensors are protected against ESD failure, temporary distortion signals may appear at the output.

Table 1: Cable versus Cable Length

Part Number	NEMA 4X Cable Length
086568A0016	16 Ft.
086568A0032	32 Ft.
086568A0064	64 Ft.
086568A0112	112 Ft.

Note: IP68 cable available by special order.

## Cable Grounding and Ground Loops

In order to provide proper shielding and prevent ground loops, cable grounding should be carefully considered.

For sensors using *two conductor/shielded cable*, the power is carried on one lead and the return on the other. The cable shield serves to protect the signal from ESD and electromagnetic interference (EMI). The shield should be grounded at only one point. Figure 2 shows a typical cable connection scheme.

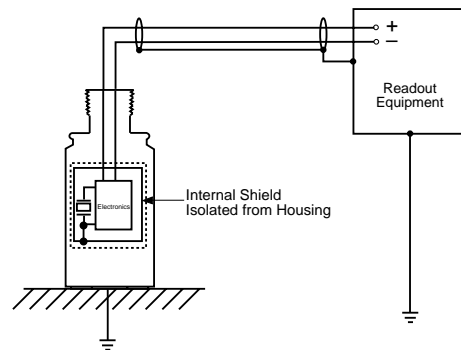

Figure 2: Multiconductor/Shield Configuration

## Cable Anchoring

After mounting the sensor, the cable should be anchored to reduce stress at the cable terminations. When securing the cable, leave enough slack to allow free movement of the sensor. Figure 3 shows a recommended cable anchoring technique.

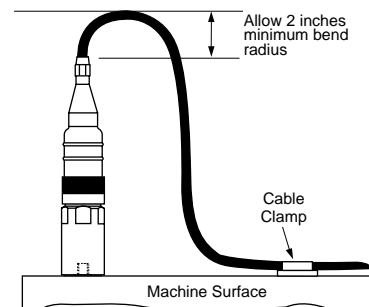

Figure 3: Cable Anchoring