

INSTRUCTION MANUAL

MODEL 563A

ELECTRONIC VIBRASWITCH MONITOR



Robertshaw Industrial Products Division
1602 Mustang Drive
Maryville, TN 37801
Telephone: (865) 981-3100 Fax: (865) 981-3168

NUMBER

909GF265C

P-2396

TABLE OF CONTENTS

Section	Page
I. DESCRIPTION	2
1.1 General	
1.2 Model Identification	
II. SPECIFICATIONS	3
2.1 Environmental	
2.2 Electrical	
2.3 Performance	
III. INSTALLATION	3-4
3.1 General	
3.2 Mounting	
3.3 Electrical Connection	
3.3.1 Power Connections (TB10 & TB11 on Figure 3-5)	
3.3.2 Vibraswitch Connections	
3.3.3 Optional Space Heater Connections (See Figure 3-5)	
3.3.4 External Contacts for Machine Control (See Figures 3-5 and 3-6)	
3.3.5 Optional Remote: Pushbutton and Alarm Indicator (See Figure 3-5)	
3.3.6 Optional Remote Vibration Shutdown Indicators (See Figure 3-5)	
IV. OPERATION	10-11
4.1 Operating Controls	
4.2 Startup Procedure	
4.3 Operation Procedure	
4.4 Operator Test	
V. MAINTENANCE	11
5.1 Troubleshooting	
5.2 Calibration	
VI. PARTSLIST	12-13
6.1 General	
6.2 Microprocessor PCA for Models 563A-() (), Robertshaw Part No. 044-KX-080-01, -02	
6.3 DC Adapter PCA for Models 563A-(C,D) () Robertshaw Part No. 044-KB-940-03, -04	

ILLUSTRATIONS

Figure	Page
3-1 Case Dimensions for Weathertight Case	4
3-2 Case Dimensions for Explosion-Proof Case	4
3-3 Case Dimensions for Explosion-Proof Conduits for Pushbuttons and Pilot Lights	5
3-4 User Electrical Connections	5
3-5 System Wiring Diagram	6
3-6 Typical Control Connections for Model 563A	7
6-1 Schematic Diagram for Model 563A Microprocessor PCA	8-9
6-2 Schematic Diagram for Models 563A-(C&D) DC Adapter PCA	14

Section I — DESCRIPTION

1.1 GENERAL

The Model 563A Vibraswitch Electronic Monitor is a microprocessor-based supervisory control system designed for use with from one to eight Robertshaw Model 365 or 366 Vibraswitch Malfunction Detectors in protecting a large piece of machinery from damage due to abnormal vibration.

The Model 563A provides field-selectable Monitor Time Delay circuitry that eliminates equipment shutdown due to transients caused by temporary external vibration disturbances. The Monitor also contains circuitry which provides a Starting Time Delay to disable the Vibraswitches for a period of time during startup to allow the machine to reach its normal operating speed or condition. After the delay period in both cases, the Monitor reactivates the Vibraswitches to provide the necessary vibration protection.

1.2 MODEL IDENTIFICATION

Identify instrument models in accordance with the description and variations listed in each table. Dashes are used in the model number only in those spaces as indicated in the example below.

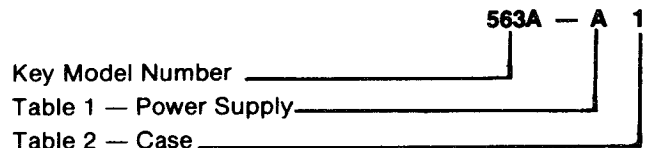

KEY MODEL NUMBER

Model No.	Description
563A	The Model 563A Vibraswitch Monitor is a microprocessor-based device programmed to differentiate between valid and invalid vibration alarms. Can be used with one to eight Vibraswitch Malfunction Detectors.

Table 1 — POWER SUPPLY

Desig.	Description
A	120 VAC, 50/60 Hz.
B	240 VAC, 50/60 Hz.
C	24 VDC
D	48 VDC

Table 2 — CASE

Desig.	Description
1	Weather-proof, NEMA 4
2	Explosion-proof, Class 1, Div. 1, Group D
3	NEMA 4X, Steel, Painted with gray epoxy enamel
4	NEMA 4X, Stainless Steel

Table 3 — ACCESSORIES

Part No.	Description	Use With
190KB083-01	Remote explosion-proof reset pushbutton and alarm indicator	563A-A()
		563A-B()
190KB083-03		563A-B()
190KB083-05		563A-C()
190KB083-02	Remote explosion-proof shutdown indicator with four lamps	563A-A()
		563A-B()
190KB083-04		563A-D()
190KB083-06		563A-C()

Section II — SPECIFICATIONS

2.1 ENVIRONMENTAL

Operating Temperature Range	-40° to +140°F. (-40° to +60°C)
Storage Temperature Range	-55° to +160°F. (-49° to +72°C)
Humidity Limit	95% RH at 100°F.
Vibration Limits	0.5G 15 to 100 Hz

2.2 ELECTRICAL

Supply Voltage:

Model 563A-A()	120 VAC±10%, 50/60 Hz 150 Watts, 167 VA Max.
Model 563A-B()	240 VAC±10%, 50/60 Hz 150 Watts, 167 VA Max.
Model 563A-C()	24 VDC, ±10% 150 Watts Max.
Model 563A-D()	48 VDC, ±10% 150 Watts Max.

Machine Power Monitor:

Voltage	Same as supply voltage
Amperage	Less than 20 mA

Alarms/Shutdown Contacts:

Terminals 3,4 & 5 on TB-9	5 amp, 28 VDC Res., 5 Amp, 120 VAC Res., 1/6 HP (2.2 Amp), 220-240 VAC
---------------------------------	--

Remote Alarm Indicator:

Terminals 5 & 6 on TB-1 thru TB-8 and terminals 6 & 7 on TB-9	
Model 563A-A	120 VAC, 25 Watts Maximum
Model 563A-B	120 VAC, 25 Watts Maximum, 1/2 wave rectified
Model 563A-C	24 VDC, 25 Watts Maximum
Model 563A-D	48 VDC, 25 Watts Maximum

Remote Reset:

Open circuit voltage	12 Volts Max.
Short circuit current	0.1 Amp Max.

2.3 PERFORMANCE

Timing Accuracy	±5% at 68°F.
Timing Range:	
Start Delay	0 to 999 Seconds
Monitor Delay	0 to 99 Seconds
Setting Resolution	1 Second

Section III — INSTALLATION

3.1 GENERAL

Examine the instrument for possible shipping damages. **IMPORTANT:** If for any reason it is determined that parts should be returned to the factory, please notify the nearest Robertshaw sales representative prior to shipment. Each unit must be properly packaged to prevent damage. Robertshaw assumes no responsibility for equipment damaged in shipment due to improper packaging.

Choose the mounting location in accordance with good instrument practice, avoiding extremes of temperature, humidity and vibration (see Section II — Specifications).

3.2 MOUNTING

The Model 563A may be mounted in any position on any appropriate flat surface. However, the weather resistant models must be mounted in a position where the illuminated reset pushbutton and the internal indicators can be easily observed by the operators. The pushbutton must also be readily accessible to the operator.

Refer to Figure 3-1 and 3-2 for mounting dimensions of the two housings and Figure 3-3 for the remote explosion proof indicator lights and pushbutton.

3.3 ELECTRICAL CONNECTIONS

WARNING

Shut off the power supply to this unit before wiring or making any changes to the wiring. Voltages as high as 240 VAC may be encountered.

All electrical connections to the Model 563A are made to terminal strips located inside the enclosure. Access holes for wiring are provided in the base of the enclosures as shown in Figures 3-1 and 3-2. See Figure 3-4 for user connections and Figure 3-5 for a complete wiring diagram of the system. Figure 3-6 shows the connections for a typical system.

3.3.1 Power Connections (TB10 & TB11 on Figure 3-5)

CAUTION: Make certain that the HOT and NEUTRAL wires to both the SUPPLY (terminal 1 & 2) and the Machine Power Monitor (Terminals 3 & 4) are connected to the proper "N" and "H" terminals.

- a. Connect supply voltage to terminals 1 and 2 of TB11. This must be the same voltage level that is specified on the rating plate of the monitor.
- b. Connect Machine Power Monitor voltage to terminals 3 and 4 of TB10. This power is normally taken from the motor starter contacts and initiates the start time delay in the Vibraswitch Monitor. This voltage must be the same level as the Supply voltage.
- c. Connect all chassis ground wires to the chassis ground terminal.

3.3.2 Vibraswitch Connections

TB-1 through TB-8 can be connected to one or more Vibraswitches as shown in Figures 3-4 and 3-5. The Vibraswitches used with any Model 563A Monitor must have reset coils with voltages identical to the primary supply voltage of the Model 563A except Vibraswitches used with the 240 VAC version which must have a reset coil voltage of 120 VAC.

Any combination of the terminal blocks may be used if less than eight Vibraswitches are connected. For example, if only three Vibraswitches are being used, it may be more convenient to connect them to terminal strips TB5, TB6, and TB7.

NOTE: When connecting Model 365-D to the Monitor, terminals 8, 9 and 10 on the Vibraswitch will not be used. Similarly, on Model 366-D, terminals 6, 7, and 8 will not be used.

3.3.3 Optional Space Heater Connections (See Figure 3-5)

If an optional space heater is used on either the Model 365-A or 366-A, the connections to the Monitor are as follows:

	Vibraswitch Terminal No.	to	TB1 - TB8 Terminal No.
Model 365-A:	6	to	6
	7	to	2
Model 366-A:	6	to	6
	8	to	2

3.3.4 External Contacts for Machine Control
(See Figures 3-5 and 3-6)

A shutdown of the machinery being monitored can be accomplished by connecting terminals 3 and 4 of TB9 in series with one side of the power line to the machinery control device as shown in Figure 3-6. The contact ratings of the internal relay connected to terminals 3 and 4 are given in Section II — Specifications. When any of the vibraswitches connected to TB1 through TB8 produce an alarmed condition, contact terminals 3 and 4 will go to the normally open (N.O.) position and the power to the machinery control device will be interrupted, thus shutting down the machinery being monitored. This same result will be produced if the Model 563A Vibraswitch Monitor loses supply voltage.

3.3.5 Optional Remote Pushbutton and Alarm Indicator
(See Figure 3.5)

On Monitor models 563A-()2, which do not have an integral pushbutton or alarm indicator, a remote pushbutton can be connected to terminals 1 and 2 and a remote alarm indicator to terminals 6 and 7 of TB9.

3.3.6 Optional Remote Vibration Shutdown Indicators
(See Figure 3-5)

On Monitor models 563A-()2, where the LED vibration shutdown indicators inside the enclosure are not visible, remote indicators (see Figure 3-3) can be connected to terminals 5 and 6 of TB1 through TB8 as desired. If multiple indicators are being used, only one connection need be made to terminal 6 on one TB (TB1-TB8) if the common side of all the lights are connected as shown in Figure 3-5.

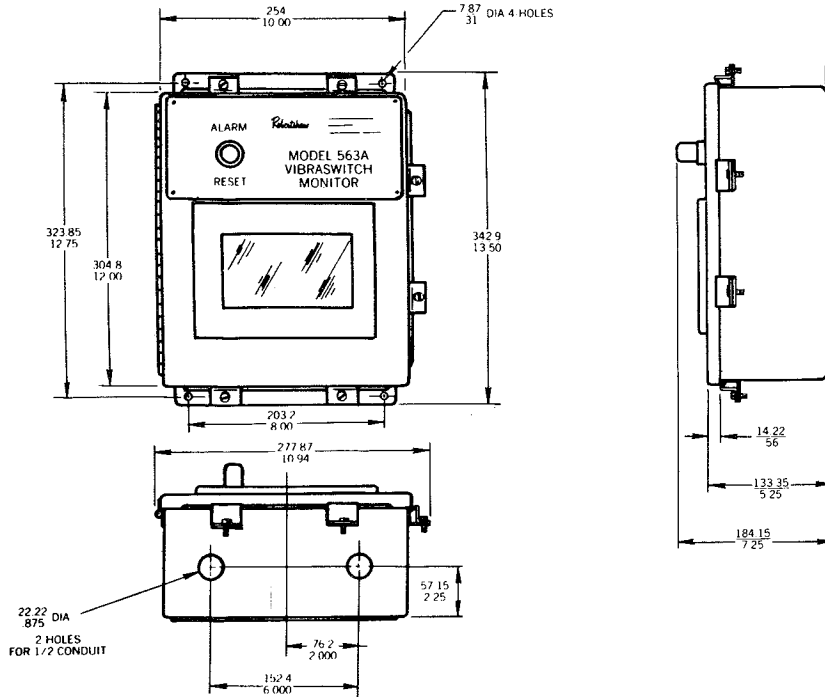

Figure 3-1. Case Dimensions for Weathertight Case, Model 563A-() (1).

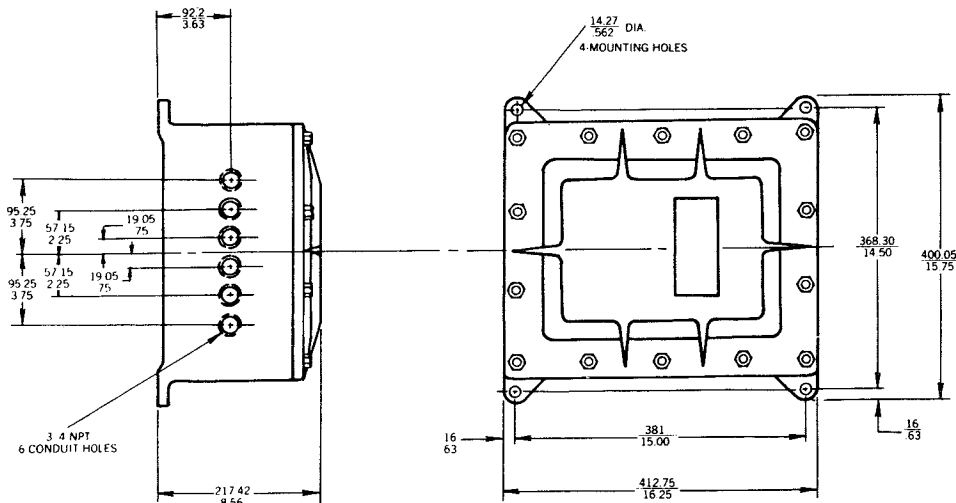

Figure 3-2. Case Dimensions for Explosion-Proof Case, Model 563A-() (2).

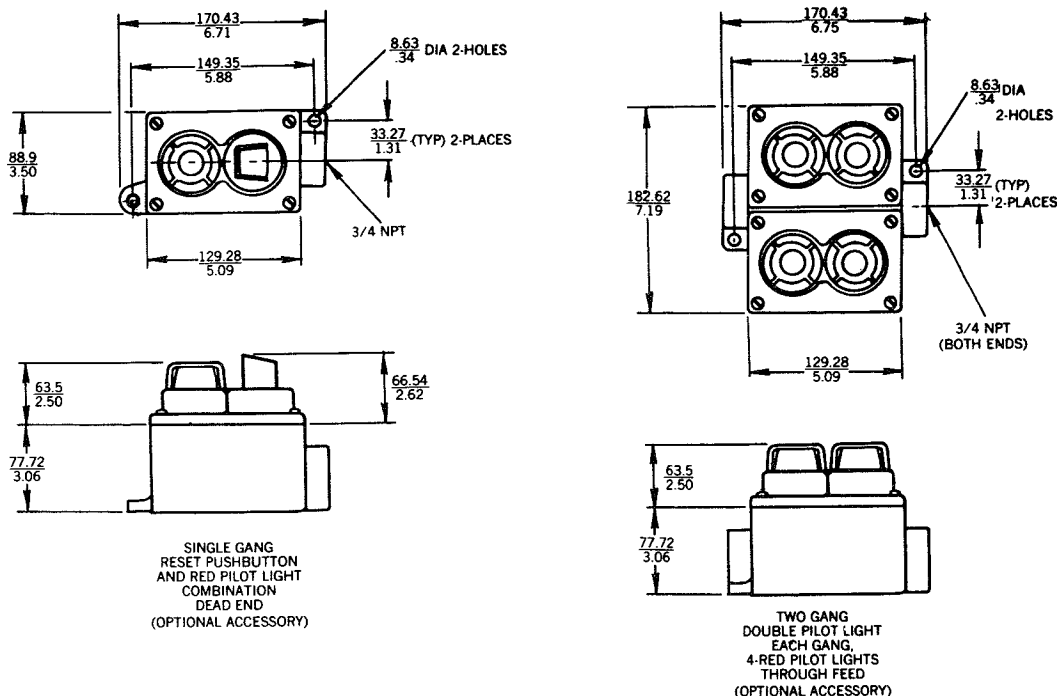

Figure 3-3. Case Dimensions for Explosion-Proof Condulets of Pushbuttons and Pilot Lights.

Terminal	Connections	
TB1-1	Vibraswitch reset coil contact #1	
TB1-2	Vibraswitch reset coil contact #2	
TB1-3	Vibraswitch N.O. contact # 3	Vibraswitch No. 1
TB1-4	Vibraswitch com. contact #4	
TB1-5	Remote vibration indicator lamp return	
TB1-6	Remote vibration indicator lamp power	
TB2-1	Vibraswitch reset coil contact #1	
TB2-2	Vibraswitch reset coil contact #2	
TB2-3	Vibraswitch N.O. contact #3	Vibraswitch No. 2
TB2-4	Vibraswitch com. contact #4	
TB2-5	Remote vibration indicator lamp return	
TB2-6	Remote vibration indicator lamp power	
TB3-1	Vibraswitch reset coil contact #1	
TB3-2	Vibraswitch reset coil contact #2	
TB3-3	Vibraswitch N.O. contact #3	Vibraswitch No. 3
TB3-4	Vibraswitch com. contact #4	
TB3-5	Remote vibration indicator lamp return	
TB3-6	Remote vibration indicator lamp power	
TB4-1	Vibraswitch reset coil contact #1	
TB4-2	Vibraswitch reset coil contact #2	
TB4-3	Vibraswitch N.O. contact #3	Vibraswitch No. 4
TB4-4	Vibraswitch com. contact #4	
TB4-5	Remote vibration indicator lamp return	
TB4-6	Remote vibration indicator lamp power	
TB5-1	Vibraswitch reset coil contact #1	
TB5-2	Vibraswitch reset coil contact #2	
TB5-3	Vibraswitch N.O. contact #3	Vibraswitch No. 5
TB5-4	Vibraswitch com. contact #4	
TB5-5	Remote vibration indicator lamp return	
TB5-6	Remote vibration indicator lamp power	

Terminal	Connections	
TB6-1	Vibraswitch reset coil contact #1	
TB6-2	Vibraswitch reset coil contact #2	
TB6-3	Vibraswitch N.O. contact #3	Vibraswitch No. 6
TB6-4	Vibraswitch com. contact #4	
TB6-5	Remote vibration indicator lamp return	
TB6-6	Remote vibration indicator lamp power	
TB7-1	Vibraswitch reset coil contact #1	
TB7-2	Vibraswitch reset coil contact #2	
TB7-3	Vibraswitch N.O. contact #3	Vibraswitch No. 7
TB7-4	Vibraswitch com. contact #4	
TB7-5	Remote vibration indicator lamp return	
TB7-6	Remote vibration indicator lamp power	
TB8-1	Vibraswitch reset coil contact #1	
TB8-2	Vibraswitch reset coil contact #2	
TB8-3	Vibraswitch N.O. contact #3	Vibraswitch No. 8
TB8-4	Vibraswitch com. contact #4	
TB8-5	Remote vibration indicator lamp return	
TB8-6	Remote vibration indicator lamp power	
TB9-1	Remote reset switch contact #1	
TB9-2	Remote reset switch contact #2	
TB9-3	Com.	External contacts for machine control
TB9-4	N.O.	
TB9-5	N.C.	
TB9-6	Remote alarm indicator lamp return	
TB9-7	Remote alarm indicator lamp power	
TB10-4 H	Machine power on signal 120V 50/60 Hz	
TB10-3 N	Machine power on signal neutral	
TB11-2 H	120V 50/60Hz power	
TB11-1 N	Neutral for 120V 50/60 Hz power	

Chassis ground to be connected to conduit/earth ground.

Figure 3-4. User Electrical Connections.

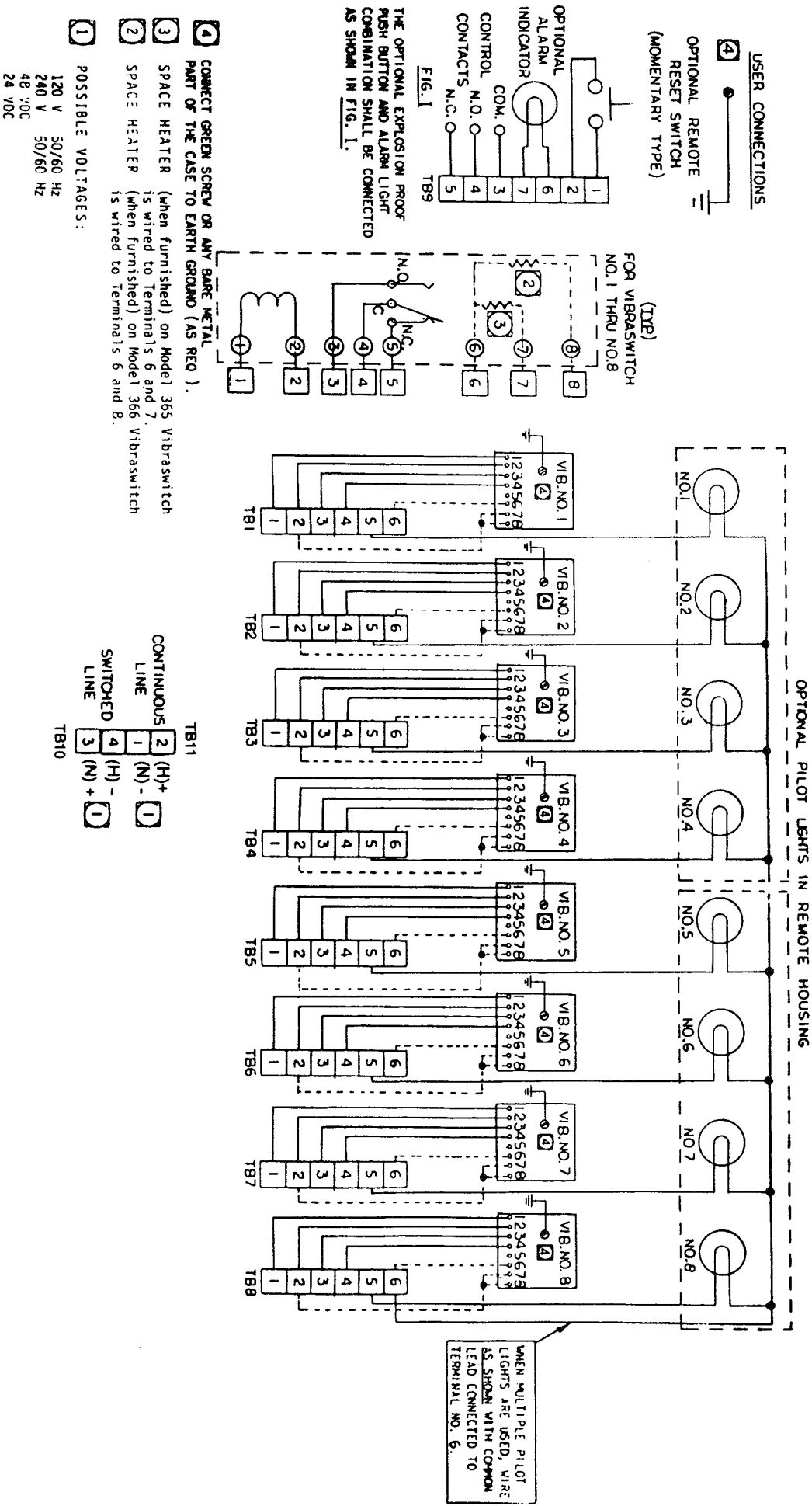

Figure 3-5. System Wiring Diagram.

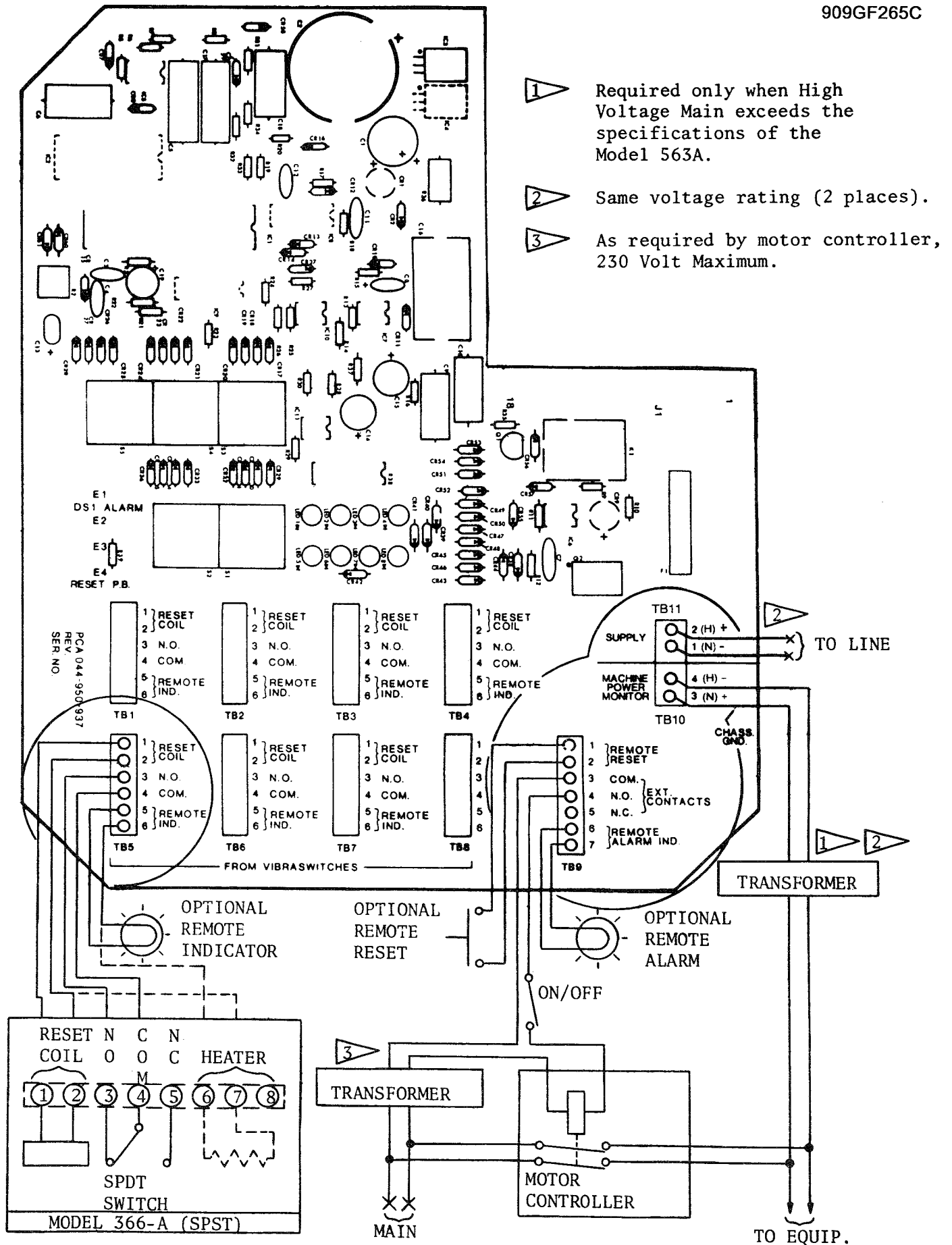
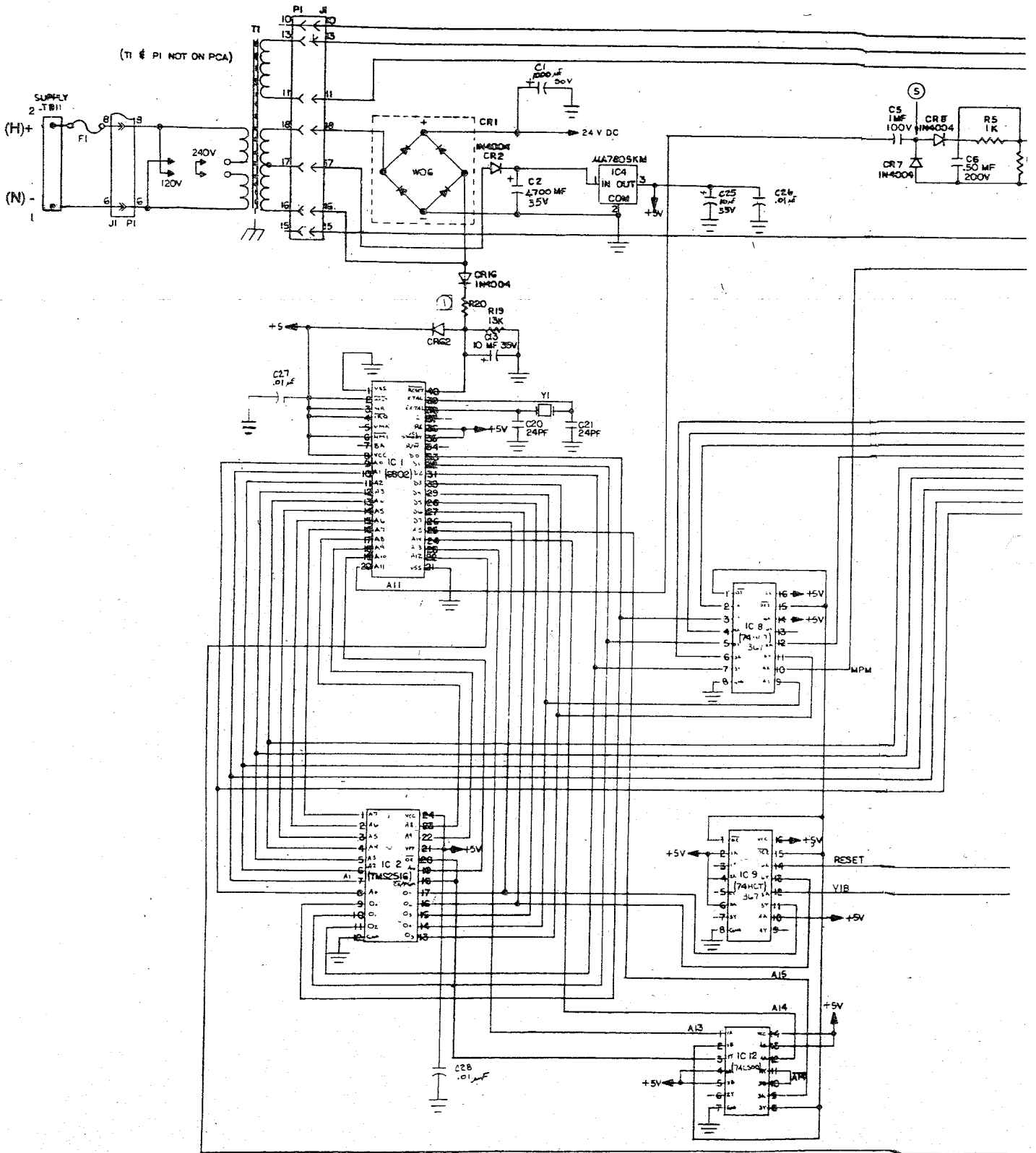
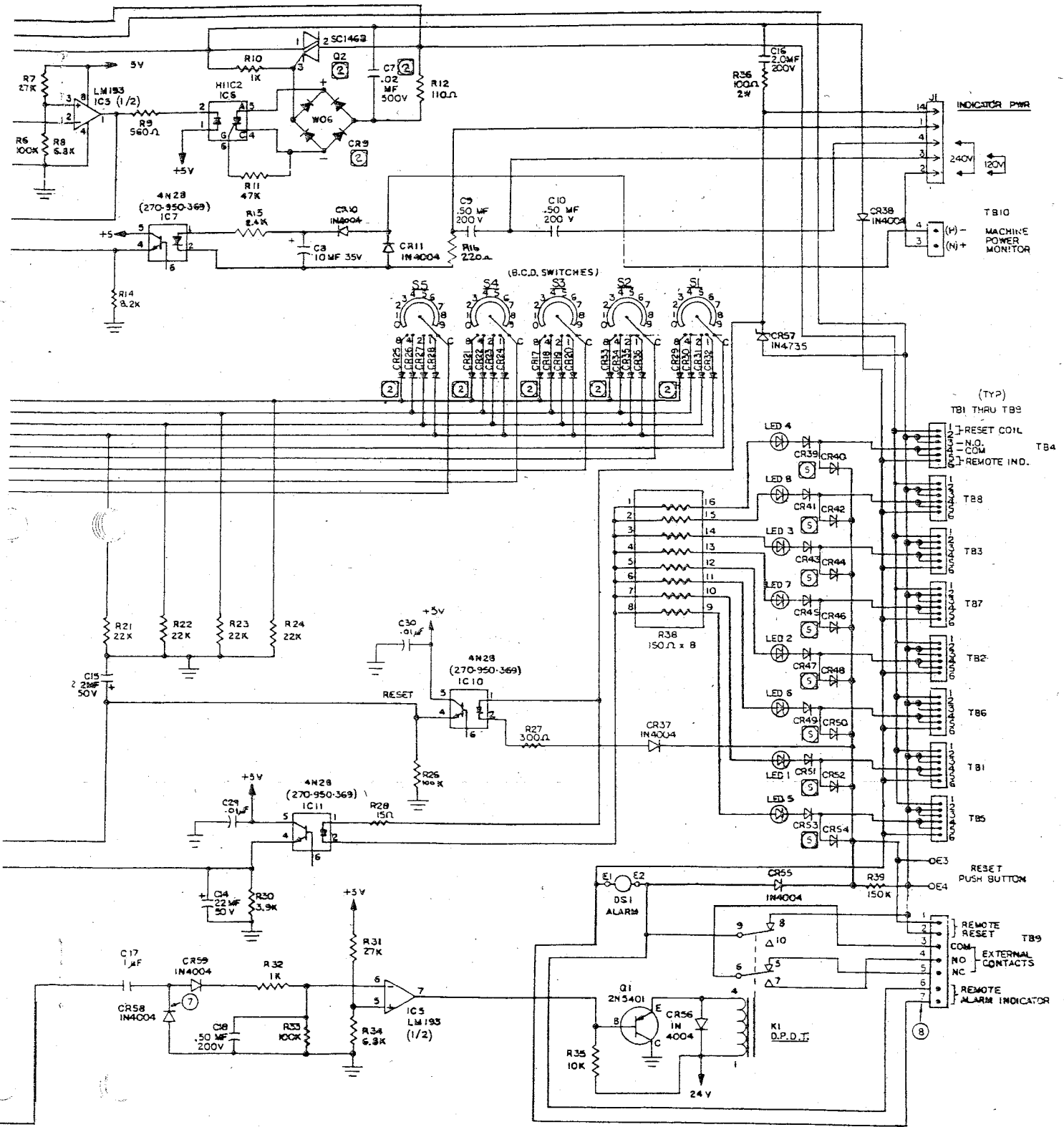

Figure 3-6. Typical Control Connections for the Model 563A.



NOTES (UNLESS OTHERWISE SPECIFIED):
 ① R20 FOR AC POWER VERSION IS PART NO. 220GD40R (22K)
 R20 FOR DC POWER VERSION IS PART NO. 220GD41R (56K)
 ② OMIT FOR DC POWER VERSION

Figure 6-1. Schematic Diagram
Robertshaw Part



for Models 563A-() () Microprocessor PCA,
No. 044KB080-01 and -02.

Section IV — OPERATION

4.1 OPERATING CONTROLS

Most of the operating controls listed below are mounted on the PCA inside the enclosure and are visible through the window in the door. The ALARM RESET pushbutton is mounted on the cover of the weatherproof unit. The ALARM RESET pushbutton and INDICATOR light are mounted remotely when used on the explosion-proof unit.

Alarm Reset — This is a combination indicator light and pushbutton. The indicator light illuminates when any one of the Vibraswitches connected to the Monitor produces an alarmed condition. The pushbutton, when depressed and released, performs the following functions.

1. Resets all tripped Vibraswitches.
2. Turns OFF the indicator light and LEDs that were illuminated due to the "alarmed" condition.
3. When depressed for at least 1/2 second, generates the signal that resets the internal circuitry to the initial "startup" conditions.
4. Resets the alarm/shutdown contacts to their normal state.
5. In the depressed position, illuminates the indicating light in the ALARM RESET pushbutton and all eight of the Vibraswitch indicator lights to act as a lamp test.

For the explosion-proof Monitor, the remote ALARM RESET pushbutton and INDICATOR light combination shown in Figure 3-3 can be used to perform the functions listed above.

Vibraswitch LEDs — These LEDs are located in the middle of the PCA and are numbered 1 through 8 to correspond with the Vibraswitch connection terminal strips TB1 through TB8. Each of the LEDs illuminates to indicate that the Vibraswitch connected to the corresponding terminal strip (i.e. LED 1 and TB1) has produced an alarmed condition. The illuminated LED will be turned OFF when the ALARM RESET pushbutton is depressed and released. For the explosion-proof models, where these LEDs are not visible, remote indicating light assemblies shown in Figure 3-3 can be used.

Start Delay — These switches set and indicate the value of the Start Time Delay. They can be adjusted from 000 to 999 seconds using a small flat-blade screwdriver or similar tool. The switch farthest left indicates hundreds of seconds, the middle switch indicates tens of seconds, and the switch on the right indicates individual seconds. The Start Time Delay circuitry inhibits monitoring from the time a machine is first started until it reaches its normal operating speed and condition. When the machine power monitor voltage (normally supplied by the start circuit of the machine being monitored) is applied to TB-10 and goes from OFF to ON, the Start Time Delay is initiated. It can also be initiated by pressing and releasing the ALARM RESET pushbutton. This delay is terminated at the end of the time period indicated by the Start Time Delay switches. The Model 563A Monitor will then reset all Vibraswitches (if required) and commence to monitor them for excessive vibration.

Monitor Delay — These switches set and indicate the value of the Monitor Time Delay. They can be adjusted from 00 to 99 seconds using a small flat-blade screwdriver or similar tool. A monitor Time Delay period is initiated when any Vibraswitch produces an alarmed condition due to excessive vibration. If the vibration continues to the end of this period, the alarm and/or shutdown contacts

will actuate and the red indicator within the ALARM RESET pushbutton will turn ON. One of the LEDs on the PCA will also come ON to indicate which Vibraswitch caused the alarm condition. After an alarm and/or shutdown condition occurs, the alarmed Vibraswitch will remain tripped until a complete "restart" is initiated or the ALARM RESET pushbutton is depressed and released, which will cause the reset of all Vibraswitches and the reset of the internal circuitry to the initial "Startup" conditions. This action also returns the alarm/shutdown contacts to their normal state and turns OFF the red indicator light and LED.

4.2 START-UP PROCEDURE

CAUTION

CAUTION: Before performing the following procedure, each of the Model 365 or 366 Vibraswitches to be monitored must be properly mounted on the machine and adjusted to the desired operating level as specified in the instruction manual for each Vibraswitch.

After the Model 563A Vibraswitch Monitor has been installed and all the desired electrical connections made, the normal sequence of operations to place the unit into operation is as follows. This procedure is to be followed the first time power is applied to a new installation or any time that the configuration of an existing system has been changed.

- a. Turn ON the supply power connected to terminals 1 and 2 of TB11. If the Alarm Indicator light in ALARM RESET pushbutton is ON, depress the ALARM RESET pushbutton to reset any Vibraswitches that are in the "alarmed" condition.

NOTE: During normal daily operation, power should be applied to terminals 1 and 2 of TB11 before the machine being monitored is started. The power should also remain ON after the machine being monitored is turned OFF and it should remain ON until all mechanical motion in machine has stopped, especially if the machine goes through a mechanical resonant condition during the winddown period. Following this procedure will prevent any of the Vibraswitches from going to the "alarmed" condition during startup or winddown of the machine being monitored.

- b. Based on experience with the machine being monitored, set the START DELAY switches to the time (0 to 999 seconds) that it takes the machine to reach equilibrium after being started. In a similar manner, set the MONITOR DELAY switches to a period (0 to 99 seconds) that is slightly longer than the duration of the normal system transient vibration periods.
- c. Apply power to the machine being monitored and, if necessary, increase the START DELAY and MONITOR DELAY switch settings until the monitored machine does not shut down during normal startup and operation. These settings are affected by the sensitivity settings of each Vibraswitch as well as the nature of the system vibration pattern.
- d. The system is now ready for normal operation.

4.3 OPERATION PROCEDURE

- a. Turn ON the supply power connected to terminals 1 and 2 of TB11. If the Alarm Indicator light in the ALARM RESET pushbutton is ON, depress the ALARM RESET pushbutton to reset any Vibraswitches that are in the "alarmed" condition.
- b. Apply power to the machine being monitored and observe that the machine reaches operating equilibrium and continues to operate.

WARNING

Any alarm indication and shutdown of the machine being monitored should be thoroughly investigated before the ALARM RESET pushbutton is depressed to restart the system

- c. If there is reason to doubt the proper operation of the Model 563A Monitor, perform the "Operator Test" in paragraph 5.2 to verify the operation of the unit.

3. By turning the Model 563A Monitor power supply OFF and then ON.

- a. Set the START DELAY switches to read 000 seconds.
- b. Set the MONITOR DELAY switches to read 20 seconds.
- c. Depress the ALARM RESET pushbutton and hold it in for at least 2 seconds.
- d. After releasing the ALARM RESET pushbutton, but before 20 seconds have elapsed, rotate the left-most digit of the START DELAY switches one position counterclockwise so that the START DELAY switches indicate 900 seconds. This should cause the alarm/shutdown contacts to change state, thereby shutting off power to the machine being monitored. The light in the ALARM RESET pushbutton will now be illuminated.
- e. Setting the START DELAY switches to read 800 seconds will reset the alarm/shutdown contacts and start the machine being monitored but will not reset any of the Vibraswitches that have tripped to the alarmed condition. The light in the ALARM RESET pushbutton will be turned OFF but the individual LEDs will remain ON if the Vibraswitch they represent is in the alarmed condition.

- f. Setting the START DELAY switches to read 700 seconds will reset any alarmed Vibraswitches and turn OFF their indicating LEDs while the alarm/shutdown contacts will remain in their normal unalarmed position. In this position, individual Vibraswitches may be adjusted to their optimum operating point since any Vibraswitch that trips to the alarmed position will be immediately and continuously reset. The optimum point can be found by adjusting the setpoint on a particular Vibraswitch until it is just above the point where it continuously trips and resets. This point can be determined by listening to the tripping of the Vibraswitch or, if the indicating LEDs in the Model 563A Monitor are visible from the adjusting point at the Vibraswitch, the ON (tripped) and OFF (reset) action of the LED that pertains to the Vibraswitch being adjusted can be observed.

Section V — MAINTENANCE

5.1 TROUBLESHOOTING

WARNING

Hazardous voltages may be present on the terminal strips inside the enclosure. 120 or 240 VAC may be present at terminals 1 & 2 of TB11 and 3 & 4 of TB10. 120 VAC may be present at terminals 1, 2, 5 and 6 of TB1 through TB9.

Any troubleshooting should start with a visual inspection of the equipment for mechanical defects or faulty electrical connections.

Refer to Figures 6-1 and 6-2 for the schematic diagrams for the various versions of the Model 563A.

5.2 OPERATOR TEST

The procedure tests the various circuits of the Model 563A Monitor for proper operation. If all steps of the test can be successfully performed, the Monitor is in proper working condition.

WARNING

This test will shut down the machine being monitored.

NOTE: The special 700, 800, and 900 modes can only be entered by performing steps "a" through "d" below. When the monitor is in one of these special modes, the normal mode may be re-entered in any one of three ways:

1. By setting the leftmost digit to the START DELAY switches to a number other than 7, 8 or 9.
2. By depressing the ALARM RESET pushbutton.

5.3 DELAY TIME VERIFICATION PROCEDURE

- a. Turn OFF or disconnect power from the Vibraswitch Monitor.
- b. Obtain a Vibraswitch "tripped" signal either by setting the sensitivity of a Vibraswitch to a point where the Vibraswitch cannot be reset OR by connecting a jumper between pins 3 and 4 on any of the Vibraswitch connection terminals (TB1 through TB8).
- c. Reapply power to both the Supply and Machine Power Monitor of the Vibraswitch Monitor.
- d. Set the Start Delay setting to "000" and the Monitor Delay setting to "20."
- e. Depress and release the RESET button and measure the time from release of the RESET button to actuation of the Alarm LED using any accurate watch with a sweep second hand or digital seconds indicator. This time should be 20 ± 1 seconds where the ± 1 second is the $\pm 5\%$ accuracy limit specified for this instrument. NOTE: Any set of Start and Monitor Delay times may be used but best results are obtained using 20 seconds or greater.

Section VI — PARTS LIST

6.1 GENERAL

Listed below are the major subassemblies and components used in the Model 563A Vibraswitch Monitor.

Item No.	Description	Robertshaw Part No.	Used on Model
1	Microprocessor PCA (See Figure 6-1)	044-KX-080-01 044-KX-080-02	563A (A,B) () 563A (C,D) ()
2	DC Adapter PCA (See Figures 6-2)	044-KB-940-03 044-KB-940-04	563A-C () 563A-D ()
3	ALARM RESET Switch Assembly	300-KB-149-01 300-KB-149-02 300-KB-149-03	563A-C1 563A-D1 563A-(A,B)1
4	Transformer and Con- nector Assembly	330-KB-196-01 330-KB-196-02	563A-A () 563A-B ()

6.2 MICROPROCESSOR PCA FOR MODELS 563A-() (), Robertshaw Part No. 044-KX-080-01 and -02.

When the Part Number of an electrical component has been changed and the new part is not 100% interchangeable with the old part, the Effectivity Column will indicate the revision letter of the Printed Circuit Assembly (PCA) on which the various part numbers are used. The revision letter is located on the PCA at the end of the nine-digit assembly number.

Desig.	Name	Value	Robertshaw Part No.	Used on Model	Effectivity									
C1	Capacitor	1000uF, 50V	035-KB-196-07	All Models										
C2		4700uF, 35V	035-KB-197-07											
C5		1uF, 100V	035-KB-123-03											
C6		0.50uF, 200V	035-KB-125-02											
C7		0.02uF, 500V	035-HJ-060											
C8		10uF, 35V	035-KB-147-04											
C9		0.50uF, 200V	035-KB-125-02											
C10		0.50uF, 200V	035-KB-125-02											
C13		10uF, 35V	035-KB-147-04											
C14		22uF, 50V	035-KA-032-13											
C15		2.2uF, 50V	035-KB-196-10											
C16		2uF, 240V	035-KB-154-01											
C17		1uF, 100V	035-KB-123-03											
C18		0.50uF, 200V	035-KB-125-02											
C20		24pF, 500V	035-KB-176-02											
C21		24pF, 500V	035-KB-176-02											
C25		10uF, 35V	035-KB-147-04											
C26		Capacitor					563A-(A,B) ()							
thru														
C30									.01uF, 50V	035-KB-058-02				
CR1									Diode	W06	270-KB-256			
CR2									1N4004	270-KB-103-02				
CR7									1N4004	270-KB-103-02				
CR8									1N4004	270-KB-103-02				
CR9									W06	270-KB-256				
CR10	1N4004			270-KB-103-02										
CR11	1N4004			270-KB-103-02										
CR16	1N4004			270-KB-103-02										
CR17	Diode								All Models					
thru														
CR36											1N4148	270-KB-254		
CR37											1N4004	270-KB-103-02	563A-(A,B) ()	All Models
thru														
CR56														
CR57	1N4735	270-KB-072-02	All Models											
CR58	1N4004	270-KB-103-02												
CR59	1N4004	270-KB-103-02												
CR62	1N4004	270-KB-103-02	All Models											

F1	Fuse	2 amp	130-KB-006-04	563A-(A,B) ()
F1	Fuse	5 amp	130-KB-006-06	563A-(C,D) ()
IC1	Integrated Circuit	Micro Comp. 6802uP	270-KB-421	All Models
IC2		2716 (Pro.)	270-KB-800	
IC4		7805 (V. Reg.)	270-KB-610-01	
IC5		LM195	270-KB-611	
IC6		H11C2	270-KB-267	
IC7		4N28	270-KB-369	
IC8		74HCT367	270-KB-798	
IC9		74HCT367	270-KB-798	
IC10		4N28	270-KB-369	
IC11		4N28	270-KB-369	
IC12	Int. Circuit	74L500	270-KB-419	
K1	Relay	DPDT	250-KB-051-02	
LED1 thru LED8	Light Emitting Diode		190-KB-061-01	
Q1	Transistor	2N5401	270-KB-326	All Models
Q2	Transistor	SC146B	270-KB-268-02	563A-(A,B) ()
R5	Resistor	1K, ±5%	260-GD-301	All Models
R6		100K, ±5%	260-GD-501	
R7		27K, ±5%	260-GD-411	
R8		6.8K, ±5%	260-GD-321	
R9		560 ohm, ±5%	260-GD-219	
R10		1K, ±5%	260-GD-301	
R11		47K, ±5%	260-GD-417	
R12		110 ohm, ±5%	260-GD-202	
R14		8.2K, ±5%	260-GD-323	
R15		2.4K, ±5%	260-GD-310	
R16		220 ohms, ±5%	260-GD-209	
R19		13K, ±5%	260-GD-404	All Models
R20		22K, ±5%	260-GD-409	563A-(A,B) ()
R20		56K, ±5%	260-GD-419	563A-(C,D) ()
R21 thru R24				All Models
R24		22K, ±5%	260-GD-409	
R26		100K, ±5%	260-GD-501	
R27		300 ohms, ±5%	260-GD-212	
R28		15 ohms, ±5%	260-GD-105	
R30		3.9K, ±5%	260-GD-315	
R31		27K, ±5%	260-GD-411	
R32		1K, ±5%	260-GD-301	
R33		100K, ±5%	260-GD-501	
R34	Resistor	6.8K, ±5%	260-GD-321	
CR62	Diode	1N4004	270-KB-103-02	
R35	Resistor	10K, ±5%	260-GD-401	
R36		100 ohms, ±5%	260-GG-201	
R38		8X5K network	260-KB-196-07	
R39	Resistor	150K, ±5%	260-GD-505	
S1 thru S5	Switch		300-KB-151	
TB1 thru TB8	Terminal Strip		325-KB-006-06	
TB9			325-KB-006-07	
TB10	Terminal Strip		325-KB-006-02	
TB11	Terminal Strip		325-KB-006-02	
Y1	Crystal	4 mHz	070-KB-003	All Models

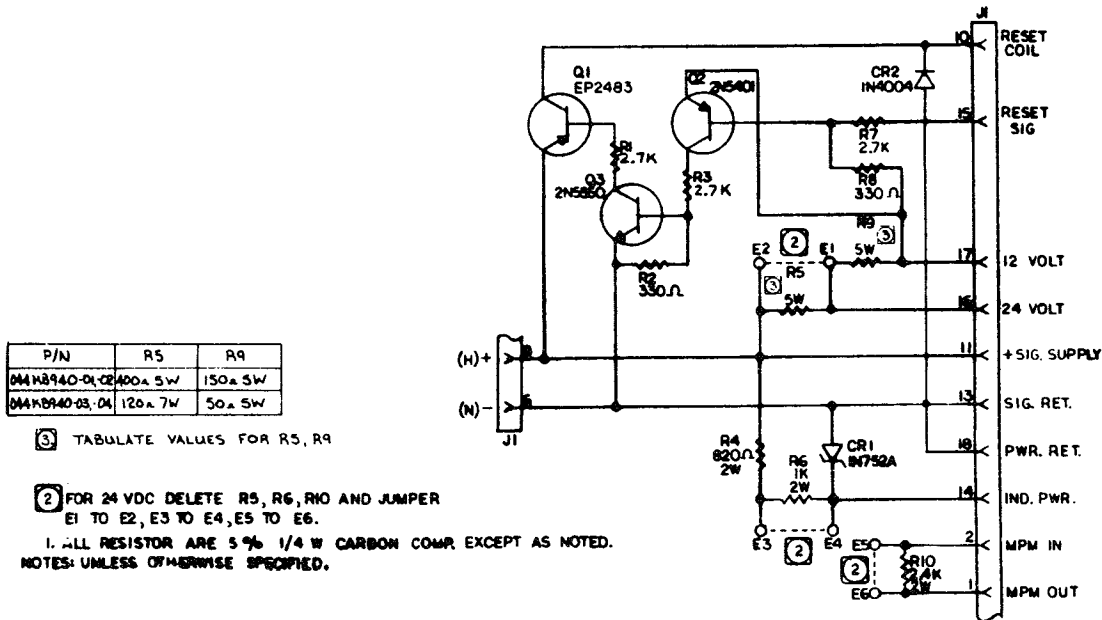

Figure 6-2. Schematic Diagram for Models 563A-(C,D) () DC Adapter PCA, Robertshaw Part No. 044-KB-940-03, and -04.

6.3 DC ADAPTER PCA FOR MODELS 563A-(C,D) ()
Robertshaw Part No. 044-KB-940-03 and -04.

Desig.	Name	Value	Robertshaw Part No.	Used on Model	Effectivity
CR1	Diode	1N752A	270-KB-296	563A-(C,D) ()	
CR2	Diode	1N4004	270-KB-103-02		
P1	Edge Connector	18-pin	055-KB-172		
Q1	Transistor	EP2483	270-KB-356	563A-(C,D) ()	
Q2	Transistor	2N5401	270-KB-326		
Q3	Transistor	2N5550	270-KB-281		
R1	Resistor	3K, 1/4W, 5%	260-GD-312	563A-(C,D) ()	
R2		330 ohm, 1/4W, 5%	260-GD-213		
R3		6.8K, 1/4W, 5%	260-GD-321		
R4		820 ohm, 2W, 5%	260-GK-223		
R5		120 ohm, 7W, 5%	260-KB-030-30		
R6		1K, 2W, 5%	260-GK-301		
R7		2.7K, 1/4W, 5%	260-GD-311		
R8		330 ohm, 1/4W, 5%	260-GD-213		
R9		50 ohm, 5W, 5%	260-KB-030-21		
R10	Resistor	2.4K, 2W, 5%	260-GK-310		

When the part number of an electrical component has been changed and the new part is not 100% interchangeable with the old part, the effectivity column will indicate the revision letter of the Printed Circuit Assembly (PCA) on which the various part numbers are used. The revision letter is located on the PCA at the end of the nine-digit assembly number.



U.S.A. and Canada
Robertshaw Industrial Products Division
1602 Mustang Drive
Maryville, TN 37801
Telephone: (865) 981-3100 Fax: (865) 981-3168
<http://www.robertshawindustrial.com>

Exports
Invensys Controls
1701 Byrd Avenue
P.O. Box 26544
Richmond, Virginia 23261-6544
Telephone: (804) 756-6500 Fax: (804) 756-6561

invensys®

Q-3825 (11/05)

Printed in U.S.A.