

# OEM Pressure Transmitter with Ceramic Sensor Model OC-1

WIKA Datasheet OC-1

## Applications

- Water filtration systems
- Process monitoring and control
- Pump and compressor systems

## Special Features

- Standard ranges from 0...30 PSI to 0...1500 PSI
- Economical, high performance design
- Environmental protection to NEMA 4 / IP 67
- Compact size



Left: OC-1 with M12 x 1 connector  
Center: OC-1 with IP 67 cable assembly  
Right: OC-1 with miniDIN connector

## Description

OC-1 pressure transmitters incorporate the WIKA ceramic thick film sensor providing performance and economy for a wide range of OEM applications. Typical applications include water treatment systems, pneumatics, compressor controls, pump protection, refrigeration and air conditioning systems.

### Dependable performance

The OC-1 features a corrosion free monolithic ceramic thick film sensor that is virtually corrosion free and provides excellent long-term stability, repeatability, and hysteresis specifications. The case is available in stainless steel or brass and provides up to NEMA 4 / IP 67 ingress protection when equipped with the optional cable connection.

Standard signal outputs include 4-20 mA, 0.1-10V, and 0.4 – 4.5V ratiometric allow the OC-1 to be integrated into many existing applications. Several signal outputs, process connections, and electrical connections are available.

The OC-1 achieves an accuracy of  $\leq 0.50\%$  full scale. The printed circuit board uses state-of-the-art surface mount technology. Modern production methods provide a low cost quality transmitter for many OEM applications requiring large quantities.

## Specifications

## Model OC-1

Pressure range	30PSI	60PSI	100PSI	160PSI	200PSI	300PSI	500PSI	1000PSI	1500PSI
<b>Maximum pressure*</b>	72PSI	145PSI	290PSI	580PSI	580PSI	580PSI	1450PSI	2900PSI	2900PSI
<b>Burst pressure**</b>	87PSI	174PSI	360PSI	725PSI	725PSI	725PSI	1740PSI	3625PSI	3625PSI
<b>Materials</b>									
■ Sealing ring				NBR {EPDM} {Others on request}					
■ Diaphragm				Ceramic Al <sub>2</sub> O <sub>3</sub> 96%					
■ Case				Brass 2.0401 (≥ 1000PSI only available in stainless steel) {Stainless steel}					
<b>Signal, supply, and load</b>									
			Output signal		Power supply		Load		
			4 ... 20 mA, 2-wire		8 ... 30 DC V		R <sub>A</sub> ≤ (U <sub>B</sub> - 8 V) / 0.02 A with R <sub>A</sub> in Ohm and U <sub>B</sub> in Volt		
			0.1 ... 10 V, 3-wire		14 ... 30 DC V		R <sub>A</sub> > 10 k		
			0.5 ... 4.5 V, ratiometric		5 ± 0.25 DC V		R <sub>A</sub> > 4.5 k		
<b>Accuracy <sup>1)</sup></b>									
			% of span		≤ 1 (limit point calibration)				
			% of span		≤ 0.5 (BFSL)				
<b>Repeatability</b>									
			% of span		≤ 0.1				
<b>1-year stability</b>									
			% of span		≤ 0.3 (at reference conditions)				
<b>Permissible temperature of</b>									
■ Medium <sup>2)</sup>	°C		-4 ... +185 °F			-20 ... +85			
■ Ambient <sup>2)</sup>	°C		-4 ... +185 °F			-20 ... +85			
■ Storage	°C		-40 ... +212 °F			-40 ... +100			
<b>Compensated temperature range</b>									
		°C		32 ... +176 °F			0 ... +80		
<b>Temperature coefficients within compensated temperature range</b>									
■ Mean TC of zero	% of span		Typ. ≤ ± 0.2 / 10 K			max. ≤ ± 0.4 / 10 K			
■ Mean TC of range	% of span		Typ. ≤ ± 0.15 / 10 K			max. ≤ ± 0.25 / 10 K			
<b>CE conformity</b>									
89/336/EWG interference emission and immunity see EN 61 326									
<b>Wiring protection</b>									
Protected against reverse polarity, overvoltage and short circuiting									
<b>Ingress protection per IEC 60529 / EN 60529</b>									
See Page 3									
<b>Weight</b>									
			lb		Approx. 0.2				

\* The specifications of WIKA's ceramic thick film sensors will not be permanently affected by pressure loads up to the burst pressure.

\*\* Exceeding the burst pressure may result in destruction of the transmitter and possible loss of media.

1) Accuracy includes linearity, hysteresis and repeatability. 30 PSI range with stainless steel case has 1.5% limit point / 0.75% BFSL accuracy. Limit point calibration in vertical mounting position with pressure connection facing down

2) Higher temperature ranges available on request.

{ } Items in curved brackets are options available at additional cost.

# Dimensions in inches (mm)

Circular connector -)  
M 12x1, IP 65  
Code: M4

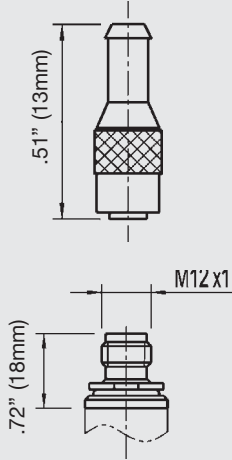

L-connector  
per DIN EN 175301-803,  
Form C, IP 65  
Code: I4

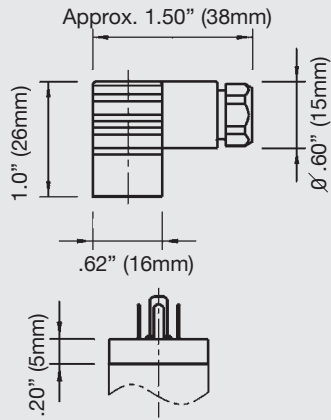

Flying leads, IP 67  
Code: DL

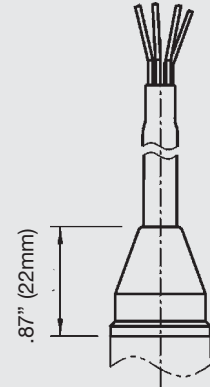

## Case

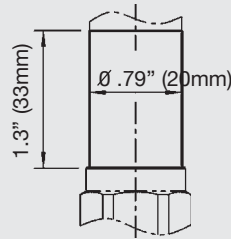

## Pressure connections

1/4NPT male  
Code: NB

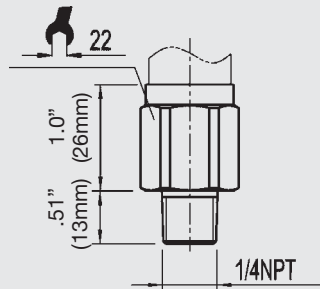

G1/4 per  
DIN 3852-E  
Code: HD

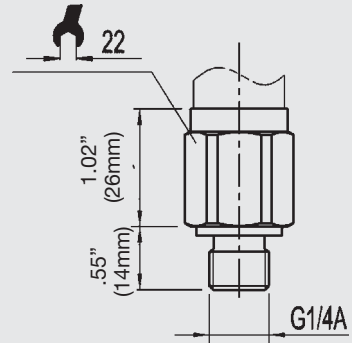

G1/4 per  
EN 837  
Code: GB

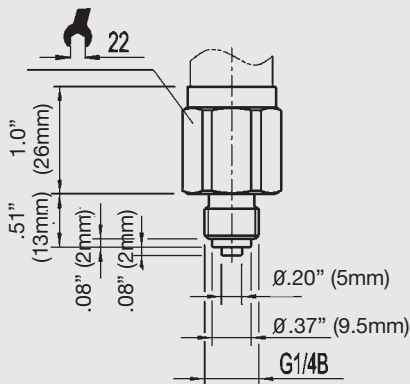

7/16-20UNF  
(Schrader)  
Code: U3

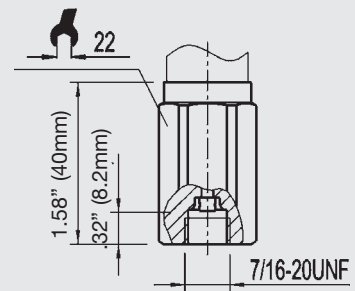

-) mating connector shown is not included

# Wiring

## 2-wire system

## 3-wire system

Circular connector  
M 12x1

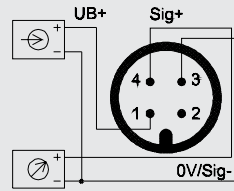
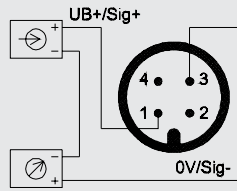

L-Connector

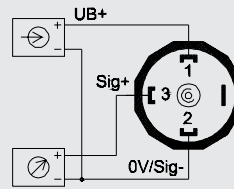
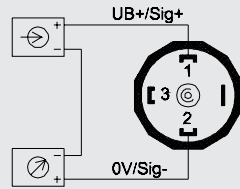

Flying leads

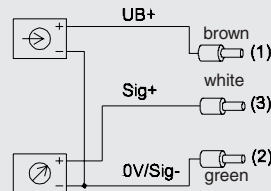
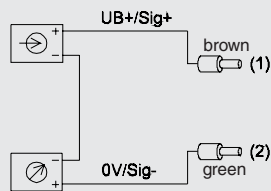

### Legend:

	power supply	Sig+ output signal positive
	load (e.g. display)	UB+ power supply positive
		0V power supply negative
		Sig- output signal negative

Specifications and dimensions in this data sheet represent the state of engineering at the time of printing. Modifications may take place and materials specified may be replaced by others without prior notice.



WIKA Instrument Corporation  
 1000 Wiegand Boulevard  
 Lawrenceville, GA 30043  
 Tel (770) 513-8200 Toll-free 1-888-WIKA-USA  
 Fax (770) 338-5118  
 E-Mail info@wika.com  
 www.wika.com