



Model 741A & 741C Probe

GENERAL DESCRIPTION

The Model 741A is a general purpose high gain rigid probe for use with Robertshaw capacitance instruments. It is used for level measuring applications involving liquids or dry materials. Available either bare (non-insulated) or Teflon insulated for use in conductive solutions. The Teflon electrode insulation has a Teflon wall thickness of 1/32" over a 7/16" 316 stainless steel sensing rod. The Teflon insulated probe is recommended for use on low viscosity liquids and low density granular materials. (For abrasive or agitated products, see Robertshaw Model 728B Heavy Duty probes.)

The Model 741A Probe has been designed to ensure long, trouble-free life. Extra tight fitting Teflon insulation has been incorporated into the design of the Model 741A Probe series. This insulation is continuous through the total length of the probe including the gland with an internal stainless steel sheath over the Teflon inside the gland. If a seal should break down and allow leakage into the gland, this internal construction is such that the measurement will not be affected and reliable readings will continue.

The Model 741A Probe, except as noted, conforms to the requirements of the National Association Of Corrosion Engineers (NACE) specification MR0175-88 (Material requirements For Resistance To Sulfide Stress Cracking For Oilfield Equipment).

The Model 741C Probe is a Model 741A Probe that has been registered in Canada as a pressure containing fitting and bears the Canadian Registration Number (CRN). All specifications for the Model 741C, except as noted are identical to the specifications for the Model 741A Probe.

APPLICATION DATA

When a probe is used with on-off (point level) instruments, it may be installed in the vessel either horizontally or vertically. For extremely small differential (deadband), the probe should be mounted in a horizontal position at the desired level point.

If the probe is to be used on a continuous level measurement application, the probe must be mounted in the vessel in a vertical position.

For low dielectric liquid applications, the Model 741A probe offers a concentric shield option over the sensing electrode.

Various gland materials and/or optional flanges are readily available to meet particular requirements.



- **Non-shortable Gland Assembly**
- **Extra tight Fitting Teflon Insulation**
- **Many Options Available to Tailor Probe to Customers' Needs**
- **Available in Lengths to 20 Feet**
- **No Moving Parts**
- **Canadian Registration Number (CRN Model 741C)**
- **Conformance to NACE MR0175-88 (Certain Models)**
- **High Gain for Low Dielectric Materials**

SPECIFICATIONS

Temperature/Pressure Ratings

Non-Insulated Probes -30" Hg to 600 psi
 Up to 100°F.
 Derated to 0 psi @ 350°F.
 Insulated Probes -30" Hg to 600 psi
 Up to 100°F.
 Derated to 0 psi @ 350°F.

Gland Capacitance 56pf

Probe Gain (insulated probe in conductive liquid) 250 pf/ft.

Sheath Capacitance 250 pf/ft.

ENGINEERING DATA

Probe Rod Material (standard) 316 stainless steel

Probe Length (maximum) 20 feet

Gland Connection Size 3/4" NPT

Probe Diameter, Non-Insulated 7/16" O.D.

Insulated 1/2" O.D.

Gland Materials:

Standard 316 stainless steel
 Optional (741A Only) Monel, Hasteloy C

Sheath Material 316 stainless steel

Concentric Shield Material 316 stainless steel

Canadian Registration Number (CRN) OH0461

BEND DIMENSIONS

Probe Style	Minimum Lengths		
	L1	L2	L3
Basic Probe	3.50"	3.50"	-
With Straight Sheath*	4.50"	3.50"	-
With Bent Sheath	3.50"	4.50"	3.50"
With Welded Flange	4.75"	3.50"	-
With Welded Flange and Straight Sheath*	4.75"	3.50"	-
With Welded Flange and Bent Sheath	4.75"	4.50"	3.50"

* Straight sheath must be at least 3.50" shorter than L1.

DIMENSIONAL DATA

MM
INCH

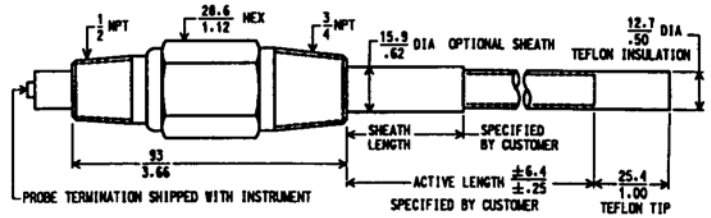

INSULATED PROBE

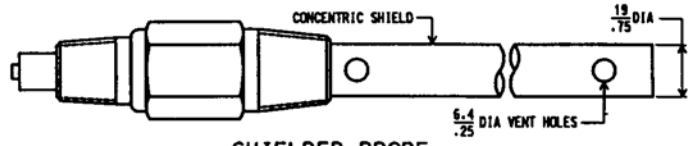

SHIELDED PROBE

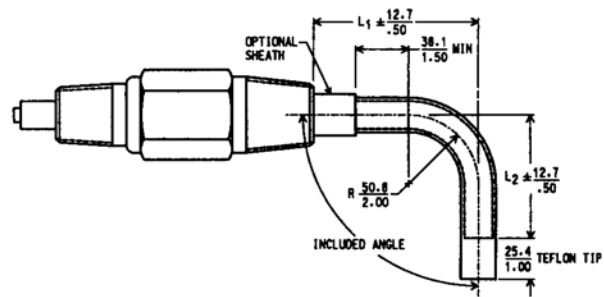

BENT INSULATED PROBE WITH STRAIGHT SHEATH

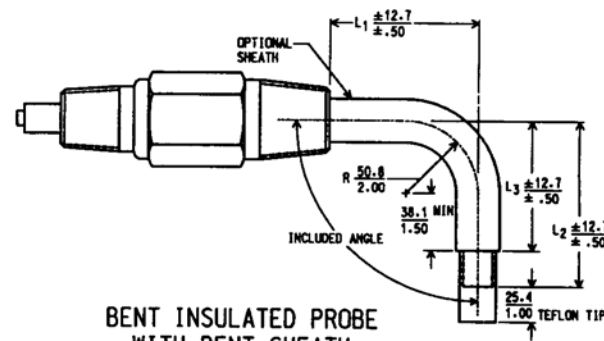

BENT INSULATED PROBE WITH BENT SHEATH

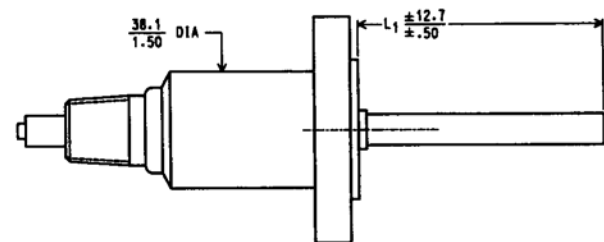

BARE PROBE WITH WELDED FLANGE

ORDERING INFORMATION

Specify complete model number according to the tables below.

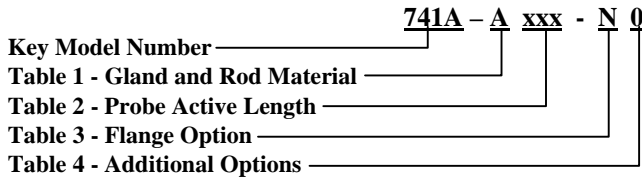

KEY MODEL NUMBER

Model No.	Description
741A	High gain rigid capacitance probe. The probe utilizes the patented, non-shortening gland assembly.
741 C	Same as 741 A except registered in Canada and bears the CRN.

Table 1- GLAND AND ROD MATERIAL

Desig.	Description
A	316 St. St. gland and 7/16" bare rod
B	316 St. St. gland with 1/2" O.D. Teflon over 7/16" rod
C*	Monel gland with 1/2" O.D. Teflon over 7/16" St. St. rod
D*	Hastelloy C gland with 1/2" O.D. Teflon over 7/16" St. St. rod

* Not available with Model 741C.
Does not conform to NACE MR0175.

Table 2 - PROBE ACTIVE LENGTH

Desig.	Description
xxx	Specify active length in inches. Maximum length is 240". For insulated probes the insertion length is 1" longer than the active length due to the Teflon Tip.

Table 3 - FLANGE OPTION

Desig.	Description
N	None
A*	Flange Screwed onto probe gland. Specify size and material.
B	Flange welded to probe gland. Specify size and material.

* Not available with Model 741C.

Table 4 - ADDITIONAL OPTIONS

Desig.	Description
0	None
1	Bent Probe. Specify Bending Dimensions. See Bending Dimension table and drawings.
2*	Sheath, same material as gland. Specify Sheath Length.
3*	Combination of 1 & 2 above.
4	Ground Wire Probe. Specify Material.
5*	Concentric shield, same material as gland.

* Does not conform to NACE MR0175.
Not available when specifying Monel or Hastelloy C Gland. (Table 1 Designations C and D).

Standard Flange Sizes

1" Class 150 Raised Face
1-1/2" Class 150 Raised Face
2" Class 150 Raised Face
3" Class 150 Raised Face
4" Class 150 Raised Face
1" Class 300 Raised Face
1-1/2" Class 300 Raised Face
2" Class 300 Raised Face
3" Class 300 Raised Face
4" Class 300 Raised Face

Standard Flange Materials

* Carbon Steel
** 316 Stainless Steel
316L Stainless Steel

* Does not conform to NACE MR0175.
** Does not conform to NACE MR0175.
Not available with 741C.

Ground Wire Materials

* 316 Stainless Steel
316L Stainless Steel
* Monel
* Hastelloy B
* Hastelloy C
* Tantalum

* Does not conform to NACE MR0175.

NOTES:

1. The insertion length for insulated probes is 1" longer than the active length due to the Teflon Tip which is required for sealing the probe. For bare probes the insertion length is the same as the active length.

2. For simple bent probes, specify dimensions L₁, L₂, the included angle and, if the sheath is bent, L₃ as shown in the drawings. For more complicated bending submit a sketch with the order.

3. Probes may be supplied with flanges of different sizes, styles and materials than listed above by special order.



U.S.A. & Canada

Robertshaw Industrial Products
1602 Mustang Drive
Maryville, Tennessee 37801
Phone: (865) 981-3100 Fax: (865) 981-3168
<http://www.robertshawindustrial.com>

Exports

Invensys Appliance Controls
1701 Byrd Avenue
P.O. Box 26544
Richmond, Virginia 23261-6544
Phone: (804) 756-6500 Fax: (804) 756-6561

invensys.

Q-4013 (11/04)

Printed in U.S.A.