

Process Pressure Transmitter Model IPT-10, standard version Model IPT-11, flush diaphragm

WIKA Data Sheet PE 86.11



Applications

- Process technology
- Chemical engineering
- Pharmaceutical industry
- Food and Beverage

Special Features

- Ex-Protection Ex ia IIC T6 per ATEX and FM
For the use in hazardous environments: Gases, vapours and mist: Zone 0, Zone 1 and Connection to Zone 0
Dust: Zone 21 and Connection to Zone 20
- Ex-Protection Ex d ia IIC T6 per ATEX and FM
For the use in hazardous environments: Gases, vapours and mist: Zone 1 and Connection to Zone 0
- High Accuracy $\leq 0.075\%$
- Scaleable measuring ranges (Turn Down up to 1 : 30)
- Configuration via DTM (Device Type Manager) according to FDT (Field Device Tool) - concept (e.g. PACTware)



Fig. left IPT-10 aluminium double chamber housing
Fig. right IPT-11 stainless steel single chamber housing

Description

With its 4 ... 20 mA / HART®, PROFIBUS® PA or FOUNDATION Fieldbus™ output signals, combined with either 'intrinsically-safe' or 'flameproof' ignition protection (according to ATEX or FM), the IPT-1X is ideally suited to applications requiring these features. The electronics of all of these transmitters, even for the 'flameproof' variant, are intrinsically safe. Internal digital processing and the use of proven sensors guarantees high accuracy and excellent long-term stability.

Versatile applicable

With available pressure ranges from 0.1 bar to 4,000 bar and a Turn Down of 1 : 30, these transmitters are suitable for almost any application. The display can be rotated within the instrument in 90° steps and, on request, an external, detached display and control module is available. The case itself can be rotated through 330° and is made of aluminium as a standard.

Where there is a requirement for greater robustness, ease-of-cleaning and chemical resistance, the single chamber variant can also be supplied in stainless steel (316 L).

Easy configuration and operation

The instrument is operated and configured by means of a 4-key membrane keypad. The operating menu is intuitive and easy-to-use and can be switched between 5 languages. Alternatively, via HART®, FOUNDATION Fieldbus™ and PROFIBUS® PA, the configurable parameters can be set using external configuration software, such as the free and manufacturer-independent PACTware™. In addition, integration into corresponding control systems is possible using the device-specific DTMs.

Specifications

Model IPT-10, standard version Model IPT-11, flush diaphragm

Pressure ranges ^{1) *}	bar	0.1	0.4	1.6	6	16	40	100	250
Over pressure safety	bar	10	2	10	35	80	80	200	500
Burst pressure	bar	12	2.4	12	42	96	400	800	1,200
Pressure ranges ^{1) *}	bar	600	1,000 ²⁾	1,600 ²⁾	2,500 ²⁾	4,000 ²⁾			
Over pressure safety	bar	1,200	1,500	2,000	3,000	4,400			
Burst pressure	bar	2,400 ³⁾	3,000	4,000	5,000	7,000			
		{Vacuum, gauge pressure, compound range, absolute pressure are available}							
Materials		with accuracy 0.1 %:				with accuracy 0.075 %:			
■ Wetted parts		(other materials see WIKA diaphragm seal program)							
Model IPT-10		Stainless steel				Stainless steel, oxide ceramics Al ₂ O ₃ , FPM/FKM			
Model IPT-11		Stainless steel {Hastelloy C4}; O-ring: NBR {FPM/FKM or EPDM}				Stainless steel, oxide ceramics Al ₂ O ₃ , O-ring: FPM/FKM {EPDM}			
■ Case		Aluminium {stainless steel 316L}							
Internal transmission fluid ⁴⁾		Synthetic oil {Listed by FDA for Food and Beverage}							
Power supply U _B	DC V	Ex ia: 14 ... 30; Ex d: 20 ... 36; {FOUNDATION Fieldbus™ and PROFIBUS® PA Ex ia: 9 ... 24}							
Signal output		4 ... 20 mA, 2-wire with modulated communication signal HART® {FOUNDATION Fieldbus™, PROFIBUS® PA}							
Permissible max. load R _A	Ohm	R _A ≤ (U _B - U _{Bmin}) / 0.023 A							
Adjustability									
■ Zero Point	%	-2.5 ... +99 (accuracy 0.1 %),				-50 ... +95 (accuracy 0.075 %)			
■ Span		Recommend max. Turn Down 1:30 (1:2 for pressure ranges > 1,000 bar)							
Input Damping	s	0 ... 999, adjustable (63 % of input signal)							
Response time (10 ... 90 %)	ms	≤ 250							
Accuracy	% of span	≤ 0.1 for pressure ranges 0.4 up to 1,000 bar ≤ 0.6 for pressure ranges > 1,000 bar {≤ 0.075 for pressure ranges up to 40 bar} ≤ 0.25 for pressure ranges 0.1 bar abs							
Behavior with Turn Down (1 : k)									
■ Turn Down of up to 1 : 5		No change of accuracy							
■ Turn Down > 1 : 5		with accuracy 0.1 % Turn Down up to 1:20 < 0.3 %				with accuracy 0.075 %: Turn Down up to 1:10 < 0.1 %			
Non-linearity	% of span	≤ 0.05 (BFSL) per IEC 61 298-2							
1-year stability	% of span	with accuracy 0.1 % ≤ 0.1 (at reference conditions)				with accuracy 0.075 % ≤ 0.05 (at reference conditions)			
Permissible temperature of									
■ Medium ⁶⁾	°C	-40 ... +105 / -25 ... +105 (NBR) / -20 ... +105 (FPM/FKM) / -40 ... +105 (EPDM)							
■ Ambience ⁶⁾	°C	-40 ... +85 (without display)				-20 ... +70 (with display)			
■ Storage	°C	-40 ... +85 (without display)				-40 ... +70 (with display)			
Compensated temperature range	°C	-20 ... +80							
Temperature coefficients in compensated temperature range									
■ Mean TC of zero	% of span	with accuracy 0.1 %: Turn Down 1:1 0.2 / 10 K Turn Down up to 1:5 0.2 / 10 K Turn Down up to 1:20 0.35 / 10 K				with accuracy 0.075 %: Turn Down 1:1 0.05 / 10 K Turn Down up to 1:5 0.1 / 10 K Turn Down up to 1:20 0.15 / 10 K			
■ Mean TC of range	% of span	≤ 0,1 / 10 K							
Ex-Protection ⁷⁾	ATEX	Category II 1G, II 1/2G, II 2G EEx ia IIC T6 II 1/2 G, II 2 G EEx d ia IIC T6 (only with 4 ... 20 mA HART®) II 1/2 D, II 2 D IP 66 T							

{ } Items in curved brackets are optional extras for additional price.

1) Other measuring ranges (e.g. 4 bar) can be set via the respective Turn Down. Even when the measuring range is present by us on (e.g. 4 bar) the standard range of (6 bar) can be set again by a reset.

2) Only Model IPT-10.

3) For Model IPT-11: The value specified in the table applies only when sealing is realised with the sealing ring underneath the hex. Otherwise max. 1,500 bar applies.

4) Not for accuracy 0.075 % and Model IPT-10 for pressure ranges > 16 bar.

5) Including non-linearity, hysteresis, non-repeatability, zero point and full scale error (corresponds to error of measurement per IEC 61 298-2).

6) Temperature limits depend on explosion protection category, temperature class and output signal (see approval documents).

7) Read the operating conditions and safety-relevant data in the approval documents in any case.

Specifications

Model IPT-10, standard version Model IPT-11, flush diaphragm

Ex-Protection ⁸⁾	FM	Intrinsically safe Div. 1 Class I, II, III Groups A, B, C, D, E, F and G and Class I, Zone 0, Group IIC Explosion proof- Intrinsically safe Div. 1 Class I Groups A, B, C, D and Class I, Zone 1, Group IIC (only with 4 ... 20 mA HART [®])
CE-conformity		89/336/EEG interference emission and immunity see EN 61 326, Interference emission limit class A and B, 94/9/EG EN 50 014 (general part), EN 50 020 (intrinsic safety), EN 50 284 (Zone 0), {EN 50 281-1 (dust)}
Functional safety ⁸⁾		SIL 2 per IEC 61 511 (up to 1000 bar)
Shock resistance	g	100 per IEC 60 068-2-27 (mechanical shock)
Vibration resistance	g	4 (5 ... 100 Hz) per IEC 60 068-2-6 (vibration under resonance)
Wiring protection		Protected against reverse polarity and short circuiting and on the instrument side
Weight	kg	approx. 1.2 (aluminium single chamber), approx. 1.5 (aluminium double chamber, high-grade steel single chamber)

{ } Items in curved brackets are optional extras for additional price.

8) Read the operating conditions and safety-relevant data in the approval documents in any case.

Dimensions in mm

Ingress Protection IP 67 per IEC 60 529

Single chamber housing aluminium
Order code: A

Single chamber housing
{stainless steel 316L}
Order code: {V}

Double chamber housing aluminium
Order code: A
in combination with Ex d or lateral display

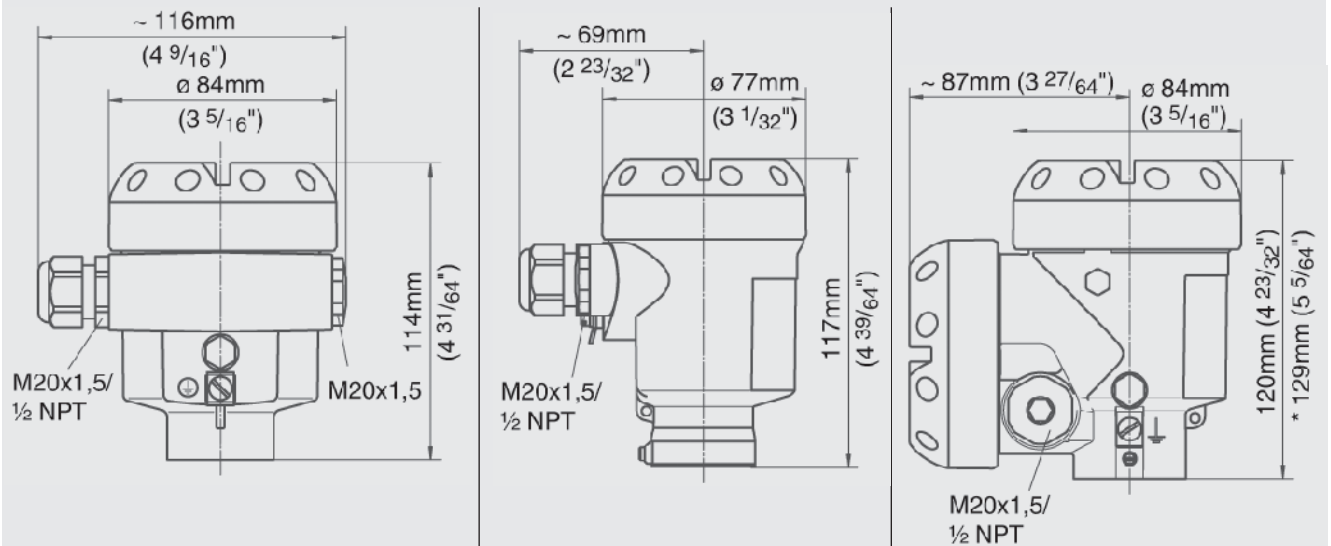

Pressure connections IPT-10

G 1/2
EN 837
max. 1,600 bar
Order code: GD

1/2 NPT
per „Nominal size for US standard tapered pipe thread NPT“,
max. 1,000 bar
Order code: ND

M16 x 1.5 female ¹⁾
from 1,600 bar
Order code: ML

M20 x 1.5 female ¹⁾
from 1,600 bar
Order code: MI

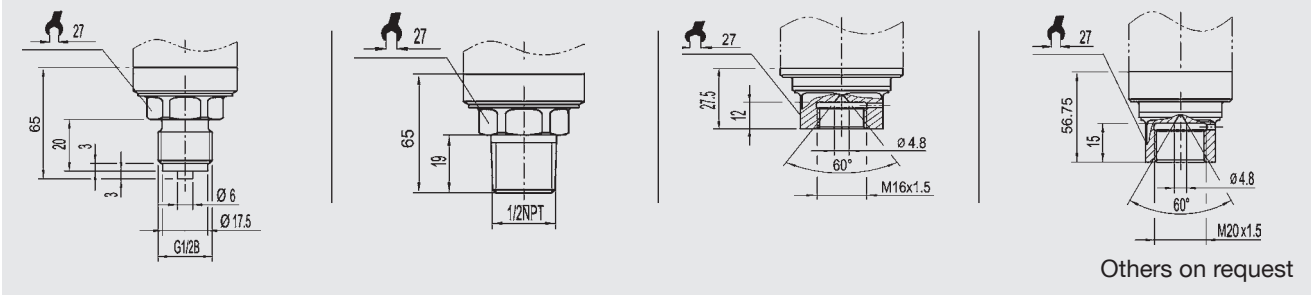

1) The respective values for your mounting position please find in the documentation of your high-pressure equipment supplier.

{ } Items in curved brackets are optional extras for additional price.

Pressure connections IPT-11, flush diaphragm

G 1
0 ... 0.4 up to 0 ... 1.6 bar
Order code: 85
(only with accuracy 0.1 % possible)

G 1/2
> 1.6 bar
Order code: 86
(only with accuracy 0.1 % possible)

G 1 1/2
without O-Ring
0 ... 0.4 up to 0 ... 16 bar
Order code: G6

G 1 per EHEDG 2),
0 ... 0.4 up to 0 ... 16 bar
Order code: 83
(only with accuracy 0.1 % possible)

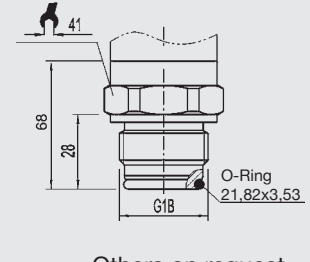
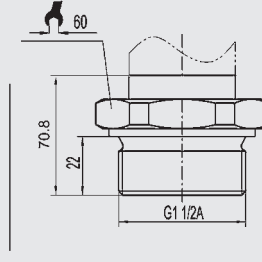
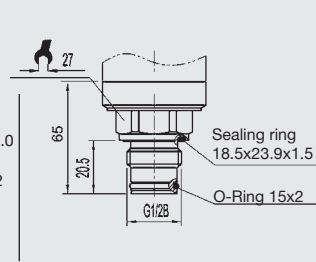
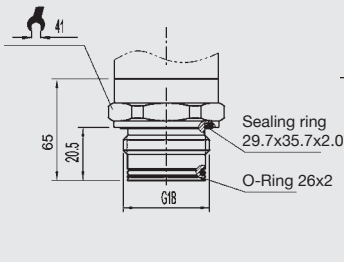

Others on request

Tri-Clamp DN 2"
max. 40 bar
Order code: SA

Tri-Clamp DN 1 1/2"
max. 16 bar
Order code: RT
(only with accuracy 0.1 % possible)

DRD
max. 40 bar
Order code: 3T

VARIVENT® Form F
max. 40 bar
Order code: 3R

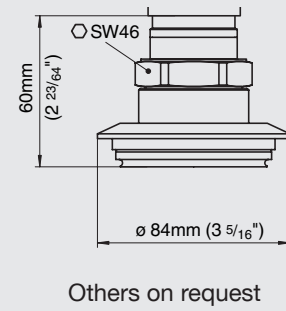
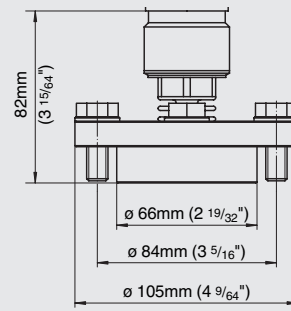
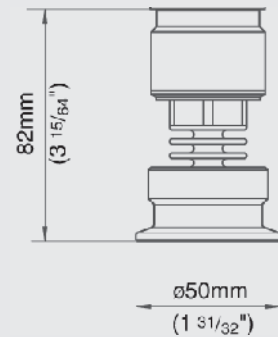
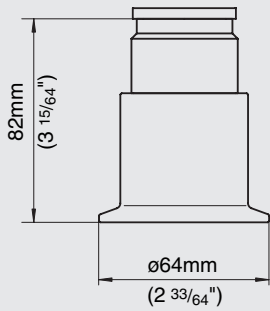

Others on request

For installation instructions see the operating instructions for this product.

Please consider also the safety instructions.

For tapped holes and welding sockets please see Technical Information IN 00.14 for download at www.wika.de -Service

2) European Hygienic Equipment Design Group

{ } Items in curved brackets are optional extras for additional price.

Wiring details

2-wire

Non Hazardous areas

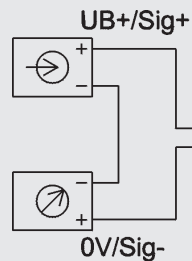

Hazardous (classified) areas

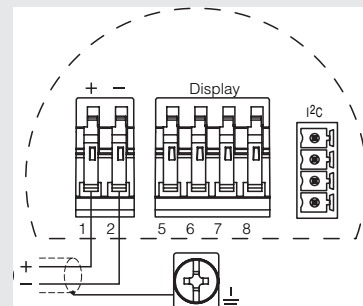

HART
COMMUNICATION PROTOCOL

Fieldbus

PROFIBUS

Legend:

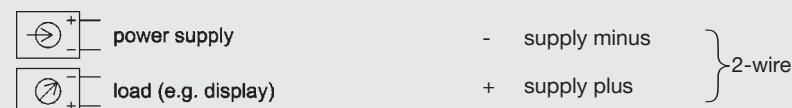

Communication between PC and transmitter for versions with HART®-communication signal

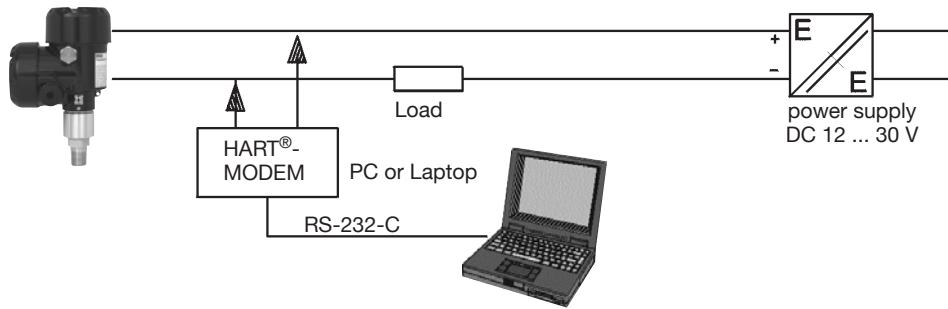

The configuration software PACTware™ starter version comes supplied with the transmitter !



Communication between HART® communicator and transmitter

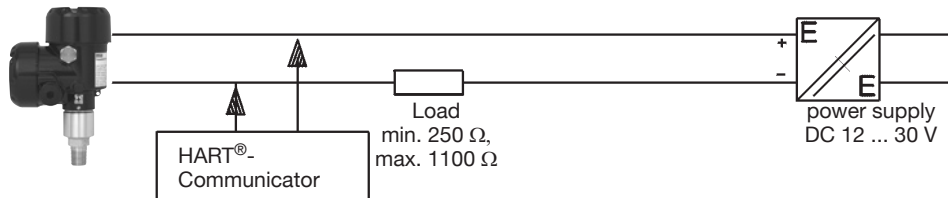

Accessories

Order-No.

Clamp for wall or pipe mounting, stainless steel	7153655
External display and menu item number, aluminium case, Ex ia Protection per ATEX	12298825
External display and menu item number, aluminium case, Ex ia Protection per FM	12298841
External display and menu item number, stainless steel case, Ex ia Protection per ATEX	12298850
External display and menu item number, stainless steel case, Ex ia Protection per FM	12298876
Display and menu item number, aluminium housing cover with vision panel	12298884
Display and menu item number, stainless steel housing cover with vision panel	12298906
HART®-Modem with USB interface	11025166
HART®-Modem with RS-232 interface	7957522
HART®-Modem with RS-232 interface and Ex-Protection per ATEX	2442791



Clamp for wall or pipe mounting



External display and menu item number

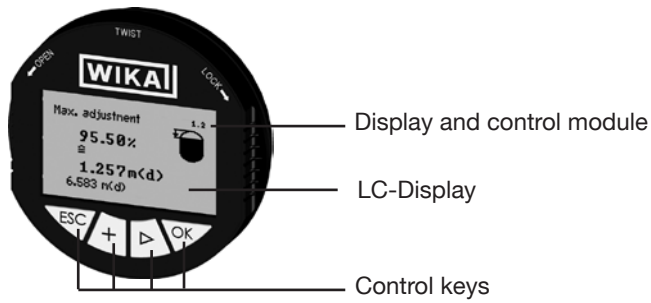

Display and menu item number

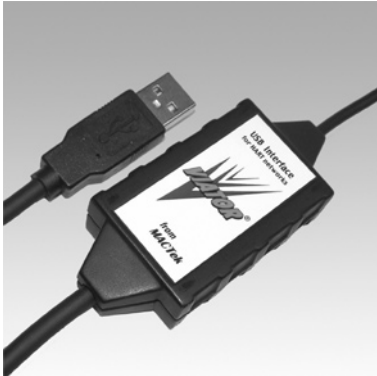

HART®-Modem with USB interface



HART®-Modem with RS-232 interface and Ex-Protection per ATEX

Specifications and dimensions given in this leaflet represent the state of engineering at the time of printing. Modifications may take place and materials specified may be replaced by others without prior notice.



WIKAI Alexander Wiegand GmbH & Co. KG
 Alexander-Wiegand-Straße 30
 63911 Klingenberg/Germany
 Tel. (+49) 9372/132-0
 Fax (+49) 9372/132-406
 E-mail info@wika.de
 www.wika.de