

SV52

2-way Normally Open
Diaphragm Isolation Construction

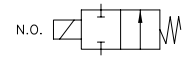

Valcor General Purpose Series



DESCRIPTION

The SV52 series is a direct acting, 2-way normally open, diaphragm isolation solenoid valve. Valcor designed this series valve with a diaphragm to isolate the valve's metallic parts from the media being handled. Available with polypropylene and PTFE body combined with Viton, EPDM or PTFE diaphragm, this series handles a wide range of fluids.

APPLICATIONS

The SV52 series is suitable for a broad range of industrial applications. Typical applications include:

- Sterilizer
- Chemical dispense
- Water treatment
- Photo processing/ink handling
- Vacuum Applications

FEATURES

- Inert construction for use with wide range of fluids
- Bubble-tight shut-off
- High flow in compact design
- Direct acting construction
- Mountable in any position



VALCOR SV52 SPECIFICATIONS

Construction

Valve Parts in Contact with Fluid

Body	PTFE, Polypropylene
Diaphragm	PTFE, Viton or EPDM

Other Parts

Body Seal	Buna-N or Neoprene
Plunger Tube	303 SS
Plunger	430F SS
Shading Coil	Copper
Plunger Stop	430F SS
Spring	303 SS

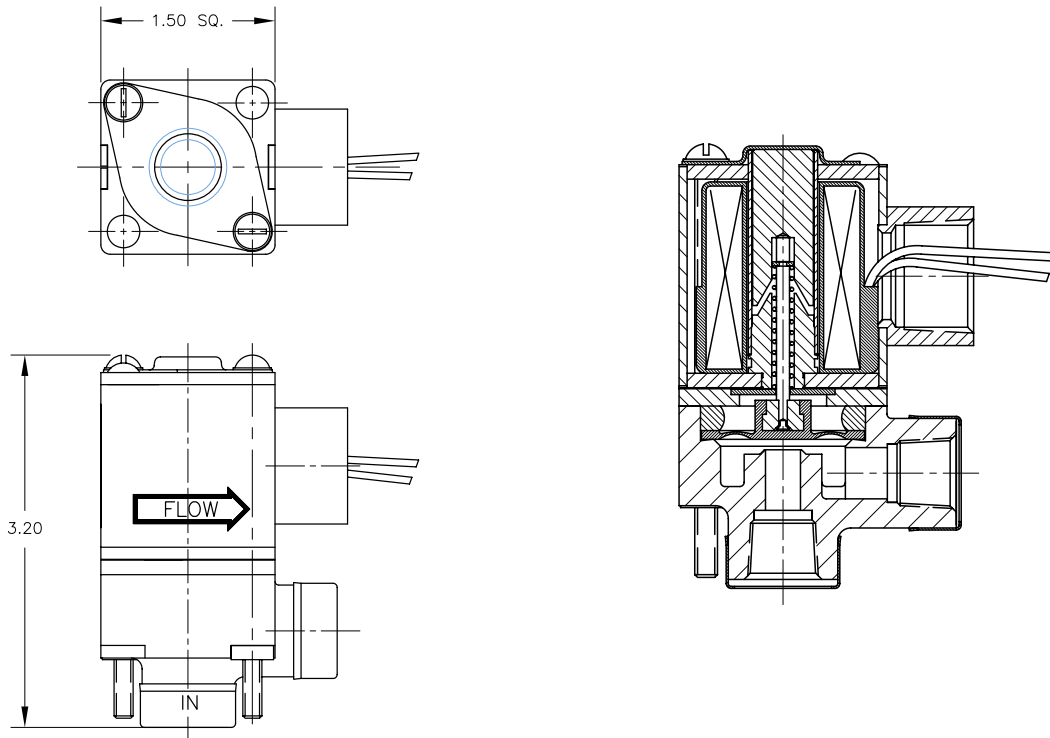

Electrical

Standard voltages	115/60 AC & 24/VDC. Consult factory for other voltages (available)
Wattage	10 watts for 115/60 Hz and 24 VDC constructions
Standard coil housing	Coils have class B insulation and 18" leads. General purpose with 1/2" NPT conduit. Explosion proof and grommeted pigtailed housing are also available. Consult factory. Replace 1st "C" in part number with "E" for explosion proof Replace 1st "C" in part number with "G" for grommeted pigtailed Example: SV52E19G24-1 for explosion proof solenoid housing

Specification for Polypropylene bodies and Viton Diaphragms

Port Size (ins.) (NPT)	Orifice Size (ins.)	C _v	Minimum Operating Pressure (PSIG)	Max. Operating Pressure (PSIG)		Vacuum at inlet** in. Hg	Voltage	Model Number
				Gas	Liquid			
1/4	1/16	0.10	10	130	125		115/60Hz	SV52C19G24-1
1/4	1/16	0.10	10	130	125		24 VDC	SV52C56G24-1
1/4	1/16	0.10				27	115/60Hz	SV52C19G24-1V
1/4	1/16	0.10				27	24 VDC	SV52C56G24-1V
1/4	1/8	0.40	8	60	55		115/60Hz	SV52C19G24-3
1/4	1/8	0.40	8	55	50		24/ VDC	SV52C56G24-3
1/4	1/8	0.40				27	115/60Hz	SV52C19G24-3V
1/4	1/8	0.40				27	24 VDC	SV52C56G24-3V
1/4	3/16	0.70	3	30	25		115/60Hz	SV52C19G24-5
1/4	3/16	0.70	3	30	25		24 VDC	SV52C56G24-5
1/4	3/16	0.70				27	115/60Hz	SV52C19G24-5V
1/4	3/16	0.70				27	24 VDC	SV52C56G24-5V
1/4	1/4	1.00	0	12	10		115/60Hz	SV52C19G24-6
1/4	1/4	1.00	0	10	6		24/ VDC	SV52C56G24-6
1/4	1/4	1.00				5	115/60Hz	SV52C19G24-6V
1/4	1/4	1.00				5	24 VDC	SV52C56G24-6V
1/4	5/16	1.40	0	8	6		115/60Hz	SV52C19G24-7
1/4	5/16	1.40	0	6	4		24 VDC	SV52C56G24-7
1/4	5/16	1.40				5	115/60Hz	SV52C19G24-7V
1/4	5/16	1.40				5	24 VDC	SV52C56G24-7V
1/4	3/8	1.90	0	6	5		115/60Hz	SV52C19G24-8
1/4	3/8	1.90	0	5	4		24/ VDC	SV52C56G24-8
1/4	3/8	1.90				5	115/60Hz	SV52C19G24-8V
1/4	3/8	1.90				5	24 VDC	SV52C56G24-8V
3/8	1/4	1.00	0	12	8		115/60Hz	SV52C19G26-6
3/8	1/4	1.00	0	10	6		24/ VDC	SV52C56G26-6
3/8	1/4	1.00				5	115/60Hz	SV52C19G26-6V
3/8	1/4	1.00				5	24 VDC	SV52C56G26-6V
3/8	5/16	1.40	0	8	6		115/60Hz	SV52C19G26-7
3/8	5/16	1.40	0	6	4		24 VDC	SV52C56G26-7
3/8	5/16	1.40				5	115/60Hz	SV52C19G26-7V
3/8	5/16	1.40				5	24 VDC	SV52C56G26-7V
3/8	3/8	1.90	0	6	5		115/60Hz	SV52C19G26-8
3/8	3/8	1.90	0	5	4		24/ VDC	SV52C56G26-8
3/8	3/8	1.90				5	115/60Hz	SV52C19G26-8V
3/8	3/8	1.90				5	24/ VDC	SV52C56G26-8V

*Part numbers shown are for polypropylene bodies and Viton diaphragms. For other materials of construction, please use part number configurator.

** Vacuum at inlet, outlet at ATM.

VALCOR SV52 SPECIFICATIONS

Specifications for PTFE bodies and PTFE Diaphragm

Port Size (ins.) (NPT)	Orifice Size (ins.)	C _v	Minimum Operating Pressure (PSIG)	Max. Operating Pressure (PSIG)		Vacuum at inlet** in. Hg	Voltage	Model Number
				Gas	Liquid			
1/4	1/16	0.10	6	130	125		115/60Hz	SV52C19T34-1
1/4	1/16	0.10	6	130	125		24 VDC	SV52C56T34-1
1/4	1/16	0.10				24	115/60Hz	SV52C19T34-1V
1/4	1/16	0.10				24	24 VDC	SV52C56T34-1V
1/4	1/8	0.40	3	60	55		115/60Hz	SV52C19T34-3
1/4	1/8	0.40	3	55	45		24/ VDC	SV52C56T34-3
1/4	1/8	0.40				24	115/60Hz	SV52C19T34-3V
1/4	1/8	0.40				24	24 VDC	SV52C56T34-3V
1/4	3/16	0.70	2	25	20		115/60Hz	SV52C19T34-5
1/4	3/16	0.70	2	20	10		24 VDC	SV52C56T34-5
1/4	3/16	0.70				24	115/60Hz	SV52C19T34-5V
1/4	3/16	0.70				24	24 VDC	SV52C56T34-5V
1/4	1/4	1.00	1.5	12	8		115/60Hz	SV52C19T34-6
1/4	1/4	1.00	1.5	5	4		24/ VDC	SV52C56T34-6
1/4	1/4	1.00				24	115/60Hz	SV52C19T34-6V
1/4	1/4	1.00				24	24 VDC	SV52C56T34-6V
1/4	5/16	1.40	1.5	10	8		115/60Hz	SV52C19T34-7
1/4	5/16	1.40	1.5	5	4		24 VDC	SV52C56T34-7
1/4	5/16	1.40				24	115/60Hz	SV52C19T34-7V
1/4	5/16	1.40				20	24 VDC	SV52C56T34-7V
1/4	3/8	1.90	1.5	6	5		115/60Hz	SV52C19T34-8
1/4	3/8	1.90	1.5	4	3		24/ VDC	SV52C56T34-8
1/4	3/8	1.90				24	115/60Hz	SV52C19T34-8V
1/4	3/8	1.90				20	24 VDC	SV52C56T34-8V

*Part numbers above are for PTFE bodies and PTFE diaphragms. For other materials of construction, please use part number configurator.

** Vacuum at inlet, outlet at ATM.

Part Number Configurator

Example Part Number: SV52C19G24-3

Numbers 1 thru 4		5	6 - 7		8	9	10		11		12										
Series	Operating Mode	Housing		Applicable Voltage		Body Material		Diaphragm Material		Pipe Connection (NPT)		Orifice Size (in.)	Option								
SV52	Normally Open	C Conduit	G Grommet	E Explosion Proof	P Grommeted Pigtails	19 115V/60 Hz	56 24/DC	G Polypropelyne	T PTFE	2 Viton	3 PTFE	8 EPDM	4 1/4"	6* 3/8"	1 1/16	3 1/8	5 3/16	6 1/4	7 5/16	8 3/8	V Vacuum

* Valve with 3/8" NPT pipe connection is only available with orifice size 1/4" or larger in polypropylene body.