

# Robertshaw

INDUSTRIAL PRODUCTS DIVISION

## Multi-Spring Diaphragm Actuators Models VC-230A, VC-231A

### DESCRIPTION

The VC-230A direct-acting model and the VC-231A reverse-acting model are spring opposed diaphragm actuators. They are designed to provide dependable On-Off or throttling operation of control valves.

They may be actuated by pneumatic signals from any suitable temperature or pressure controller.

### SPECIFICATIONS

**Diaphragm Area:** ..... 29 sq. inches (0.02m<sup>2</sup>) nominal  
**Service Connection:** ..... 1/4" - 18 NPT  
**Pattern:** ..... Enclosed Spring Type.  
**Spring Ranges:** ..... 3-15 psi (0.2-1.0 bar) standard.  
 Other ranges available.

#### Diaphragm Pressure:

100 psi (6.9 bar) max. test  
 40 psi (4.8 bar) max. working

**Maximum Stroke:** ..... 1" (25.4 mm)

**Ambient Temperature:** ..... 200°F (93°C)

#### Actuator Action:

**VC-230A** ..... Air-to-push-down

**VC-231 A** ..... Air-to-push-up

#### Materials:

**Diaphragm Housing** ..... Steel, painted with polyurethane enamel.

**Diaphragm** ..... Buna-N, Nylon reinforced.

**Diaphragm Plate** ..... Aluminum casting

**Springs** ..... Tempered MB wire, zinc plated

**Actuator Stem** ..... Stainless Steel

**Actuator Stem Guide** ..... Bronze, Self-lubricating

**Frame** ..... Cast iron.

**Stem Connector** ..... Stainless

**Stroke Indicator** ..... Aluminum



Model VC-230A

### ACTUATOR OPERATION

**Model VC-230A** - Air pressure from the controller is applied to the top of the diaphragm. As this pressure increases within the range of the load spring, the actuator stem moves down.

**Model VC-231A** - Air pressure from the controller is applied underneath the diaphragm. Increasing pressure causes the actuator stem to move upward.

The following table illustrates valve action when models VC-230A and VC-231A are used. Most Robertshaw valve styles with strokes not exceeding 1" can be furnished with either of these actuators for air-to-close or air-to-open operation.

### FEATURES

- Molded Buna-N diaphragms, nylon reinforced.
- Steel Diaphragm Cases.
- Multiple Steel Springs
- Sturdy cast iron lower frame.
- Quick disconnect valve stem construction.
- Valve position indicator.

	Model VC-230A Actuator (Air-to-Push-Down)		Model VC-231A Actuator (Air-to-Push-Up)	
	Increasing Air Pressure	Air Failure	Increasing Air Pressure	Air Failure
Direct-Acting Valve (Push down to close)	Closes	Opens	Opens	Closes
Reverse-Acting Valve (Push down to open)	Opens	Closes	Closes	Opens

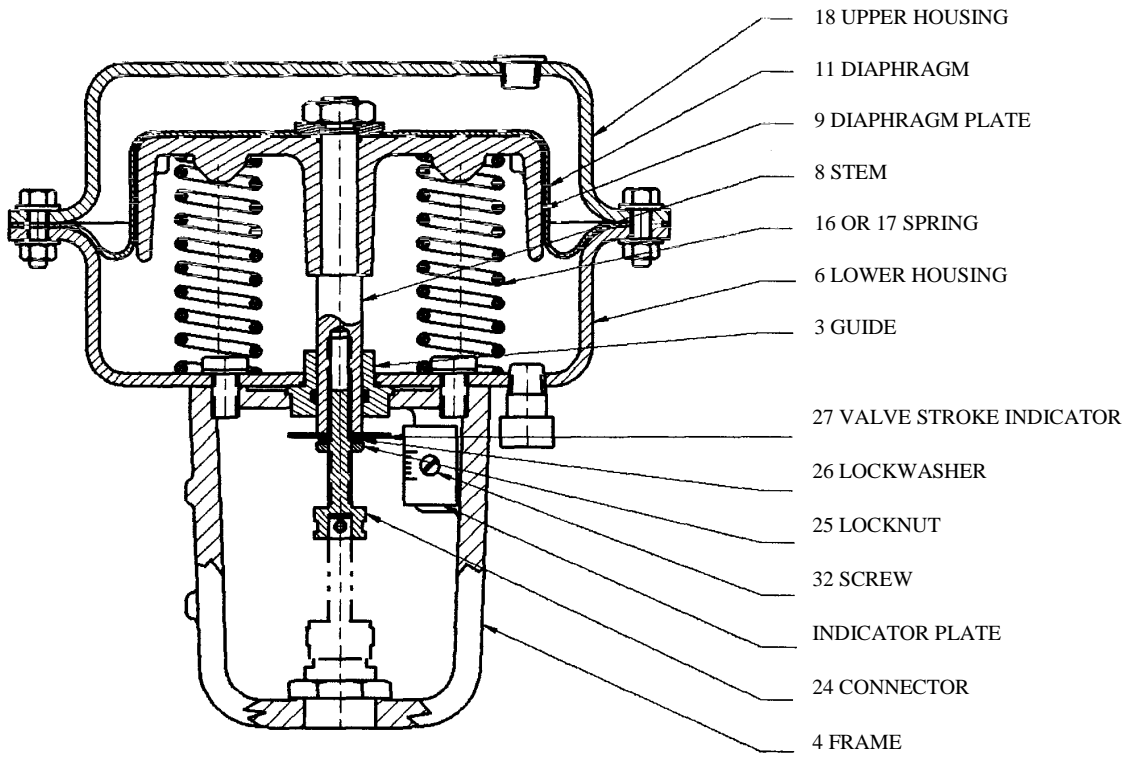

ACTUATOR ASSEMBLY  
 VC-230A (DIRECT-ACTING)

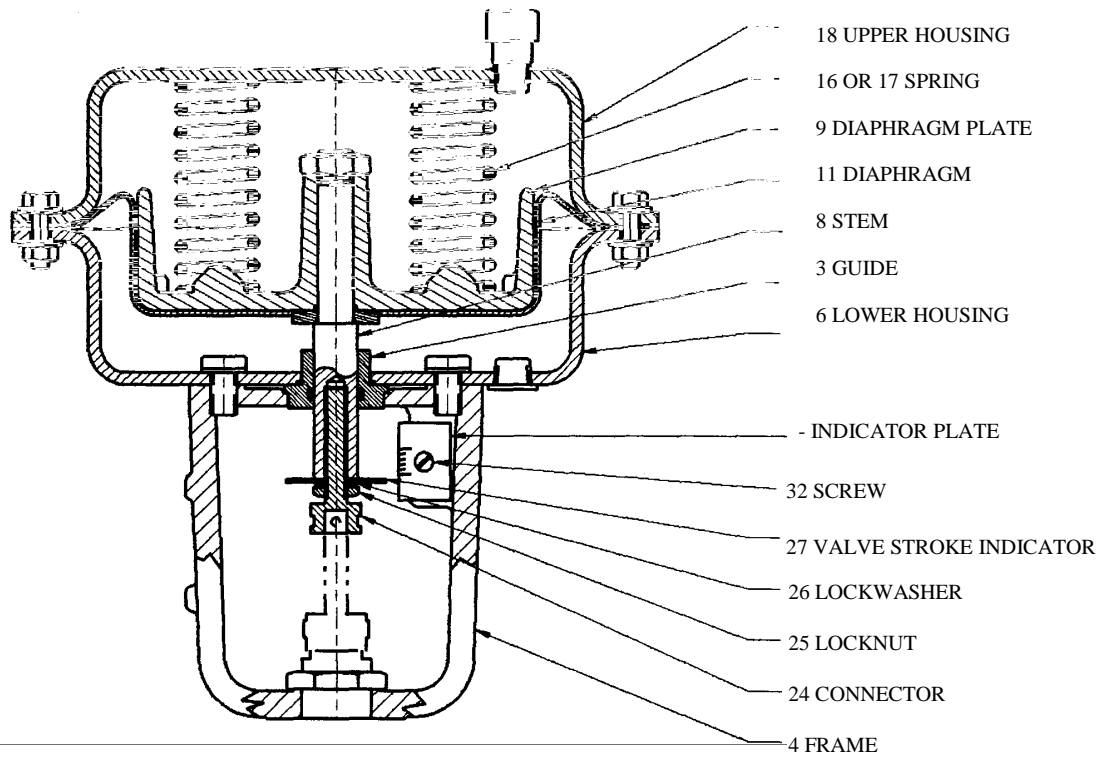

ACTUATOR ASSEMBLY  
 VC-231A (REVERSE -ACTING)

## CONTROL VALVES USED WITH VC-230A AND VC-231A ACTUATORS

### Valve Body Assembly Characteristics and Shipping Weights SINGLE SEATED VALVES

Valve Type	Body Material and Rating	Trim	Valve Size and Type of Ends	Port Size In. (mm)	Full Open C <sub>v</sub>	Shipping Weight Lbs.	Max. ΔP with 30 In. <sup>2</sup> (0.02m <sup>2</sup> ) Actuator 3-15 PSI (0.2 -1.0) bar Range
BC PERCENTAGE 1"-2" (Direct Acting Only)	Brass 250 PSI	Composition Disc. Integral Brass Seat	1" Screwed	1 (25.4)	9.3	28 (12.7)	40 (2.76)
			1 1/4" Screwed	1 1/4 (31.8)	17	30 (13.6)	40 (2.76)
			1 1/2" Screwed	1 1/2 (38.1)	25	30 (13.6)	40 (2.76)
			2" Screwed	2 (50.8)	40	39 (17.7)	40 (2.76)
BG PERCENTAGE (Direct Acting Only)	Brass 250 PSI	316 Stainless Steel	1/2" Screwed	1/2 (12.7)	2.0	24 (10.9)	125 (8.62)
			3/4" Screwed	3/4 (19.0)	5.3	25 (11.5)	125 (8.62)
			1" Screwed	1 (25.4)	9.5	28 (12.7)	125 (8.62)
			1 1/4" Screwed	1 1/4 (31.8)	15	30 (13.6)	125 (8.62)
CSS (Direct and Reverse Acting)	316 St. St. Class 150	316 Stainless Steel	1 1/2" Screwed	1 1/2 (38.1)	23	30 (13.6)	100 (6.90)
			1/2" Screwed	1/2 (12.7)	2.3	25 (11.3)	100 (6.90)
			3/4" Screwed	3/4 (19.0)	7.3	25 (11.3)	100 (6.90)
MA QUICK OPENING (Direct Acting Only) Fully Balanced	Brass 250 PSI	316 Stainless Steel	1" Screwed	1 (25.4)	9.5	25 (11.3)	100 (6.90)
			3/4" Screwed Unions	3/4 (19.0)	9.8	28 (12.7)	250 (17.2)
			1" Screwed Unions	1 (25.4)	12.8	28 (12.7)	250 (17.2)
	Cast Iron 125 PSI		1 1/4" Screwed Unions	1 1/4 (31.8)	18.6	33 (15.0)	250 (17.2)
MAS QUICK OPENING (Direct Acting Only) Fully Balanced	Cast Steel 300 PSI	316 Stainless Steel	1 1/2" Screwed Unions	1 1/2 (38.1)	26	35 (15.9)	250 (17.2)
			2" Flanged	2 (50.8)	47.5	50 (22.7)	150 (10.3)
			3/4" Screwed	3/4 (19.0)	10.5	29 (13.2)	250 (17.2)
			1" Screwed or Flanged	1 (25.4)	12.2	29 (13.2) <sup>2</sup>	250 (17.2)
			1 1/2" Screwed or Flanged	1 1/2 (38.1)	25.5	40 (18.2) <sup>2</sup>	250 (17.2)
			2" Flanged	2 (50.8)	47.8	68 (30.9)	150 (10.3)

### DOUBLE SEATED VALVES

Valve Type	Body Material and Rating	Trim	Valve Size and Type of Ends	Port Size In. (mm)	Full Open C <sub>v</sub>	Shipping <sup>2</sup> Weight Lbs. (Kg.)	Maximum ΔP with 30 in <sup>2</sup> (0.02m <sup>2</sup> ) Actuator 3-15 psi (0.2 - 1.0 bar) Range
FA end FAR QUICK OPENING (Direct end Reverse Acting) Top and Bottom Guided	Bronze 125 PSI	Brass Or Monel	3/4" Screwed Unions	3/4 (19.0)	9.3	25 (11.3)	125 (8.62)
			1" Screwed Unions	1 (25.4)	17.6	28 (12.7)	125 (8.62)
			1 1/4" Screwed Unions	1 1/4 (31.8)	22.5	30 (13.6)	125 (8.62)
			1 1/2" Screwed Unions	1 1/2 (38.1)	30.4	33 (15.0)	125 (8.62)
	Cast Iron 125 PSI	303 St. St. Plug 316 St. St. Seat	2" Flanged	2 (50.8)	59.3	50 (22.7)	100 (6.90)
			2 1/2" Flanged	2 1/2 (63.5)	82.5	63 (28.1)	100 (6.90)
			3" Flanged	3 (76.2)	130	73 (33.1)	100 (6.90)
			4" Flanged	4 (102)	226	103 (46.8)	100 (6.90)

### THREE-WAY VALVES

Valve Type	Body Material and Rating	Trim	Valve Size and Type & Ends	Port Size In. (mm)	Full Open Cv		Shipping <sup>2</sup> Weight Lbs. (Kg)	Max. ΔP with
					N.O.	N.C.		30 In. <sup>2</sup> (0.02m <sup>2</sup> Actuator
								3-15 PSI (0.2 - 1.0 bar)
Range								
<b>WA QUICK OPENING Unbalanced Mixing Service Only</b>	Brass 150 PSI	316 St. St. Upper Seat 316 St. St. Lower Seat 316 St. St. Plug	1/2" Screwed Unions	1/2 (12.7)	4.2	3.1	24 (10.9)	75 (5.18)
		316 St. St. Seats 316 St. St. Plug	3/4" Screwed Unions	3/4 (19.0)	7.8	5.6	25 (11.3)	75 (5.18)
		316 St. St. Plug	1" Screwed Unions	1 (25.4)	11.1	8.8	25 (11.3)	75 (5.18)
		316 St. St. Upper Seat 316 St. St. Lower Seat 316 St. St. Plug	1 1/4" Screwed unions	1 1/4 (31.8)	23.5	18.1	30 (13.6)	75 (5.18)
			1 1/2" Screwed Unions	1 1/2 (38.1)	31.7	25.0	32 (14.5)	75 (5.18)
<b>WCSS Unbalanced Mixing Service Only</b>	316 Stainless Class 150	316 Stainless Steel	1/2" Screwed	1/2 (12.7)	A-C 2.2 A-B 2.2		25 (11.3)	1/2 (100)
			3/4" Screwed Unions	3/4 (19.0)	A-C 4.6 A-B 4.6		25 (11.3)	3/4 (80)
			1" Screwed	1 (25.4)	A-C 9.0 A-B 9.0		25 (11.3)	1 (40)
<b>WD QUICK OPENING Balanced Mixing or Diverting</b>	Brass 100 PSI	Brass	2" Flanged	2 (50.8)	64	64	68 (30.9)	40 (2.76)
			2 1/2" Ranged	2 1/2 (63.5)	77	77	80 (36.3)	40 (2.76)
			3" Flanged	3 (76.2)	115	105	86 (39.0)	40 (2.76)
			4" Flanged	4 (102)	240	250	144 (65.4)	25 (1.73)
			5" Ranged	5 (127)	360	415	200 (90.8)	25 (1.73)
			6" Flanged	6 (152)	520	600	247 (112)	25 (1.73)
<b>WE LINEAR (Top and Bottom Guided) Unbalanced Service Mixing Only</b>	Brass 300 PI	Brass	1/2" Screwed	1/2 (12.7)	2.2	2.2	24 (10.9)	50 (3.45)
			3/4" Screwed	3/4 (19.0)	4.6	4.6	26 (11.8)	50 (3.45)
			1" Screwed Unions	1 (25.4)	9.0	9.0	28 (12.7)	50 (3.45)
			1 1/4" Screwed	1 1/4 (31.8)	18	18	31 (14.1)	50 (3.45)
			1 1/2" Screwed	1 1/2 (38.1)	25	25	30 (13.6)	50 (3.45)
			2" Screwed	2 (50.8)	40	40	40 (182)	40 (2.76)

**FOOTNOTES:**

- For complete valve body assembly specifications, see catalog sections on Control Valves.
- Shipping weights are for valve body assembly and actuator.
- Weights shown are for screwed end valves. Weights for flanged valves are: 1" - 35 lbs. (15.9 Kg); 1 1/4" - 42 lbs. (19.1 Kg); 1 1/2" - 52 lbs. (23.6 Kg)

### VALVE SIZING

All Robertshaw valve capacities are stated in terms of Cv. Use of the flow coefficient Cv offers a standard approach for valve sizing regardless of type. Cv ratings for Robertshaw valves are determined experimentally in accordance with procedures recommended by the Fluid Controls Institute.

Valve sizes may be calculated using Cv formulas or Robertshaw's Flo-Rule (valve sizing slide rule) for any set of flow conditions. When capacity requirements (pounds of steam per hour, gallons of water per minute, cubic feet of gas per hour, etc.), the supply pressures, pressure drops, and nature of fluid are known, the numerical Cv value can be obtained. This can be compared with Cv ratings tabulated for the various valve styles in the "Valve Characteristics" tables in this product specifications or on the Cv tables furnished with the Flo-Rule.

The Robertshaw Flo-Rule is available upon request from any Robertshaw representative or from the factory.

### MODEL IDENTIFICATION

**Control Valve Identification** - The identification scheme used by Robertshaw shows size, actuator type, valve style, plug characteristics, and whether direct- or reverse-acting. Viz., VC-230-FA. This is a 2" air-to-close control valve using an air-to-push-down actuator and a direct-acting double-seated style FA valve which has quick opening flow characteristics. Similarly, a 3" VC-230-FAR is a 3" air-to-open control valve using an air-to-push-down actuator and reverse-acting double seated style FA valve (FAR). "R" on the suffix indicates a reverse-acting body.

### ORDERING INFORMATION

When ordering, specify:

- Quantity.
- Control valve model number.  
(See "Control Valve Identification" above)
- Spring range required.
- Valve type, size and action.  
(See "Control Valve Identification")
- Medium through valve.
- Supply pressure to valve.
- Pressure drop.
- Any special characteristics of the flowing medium.

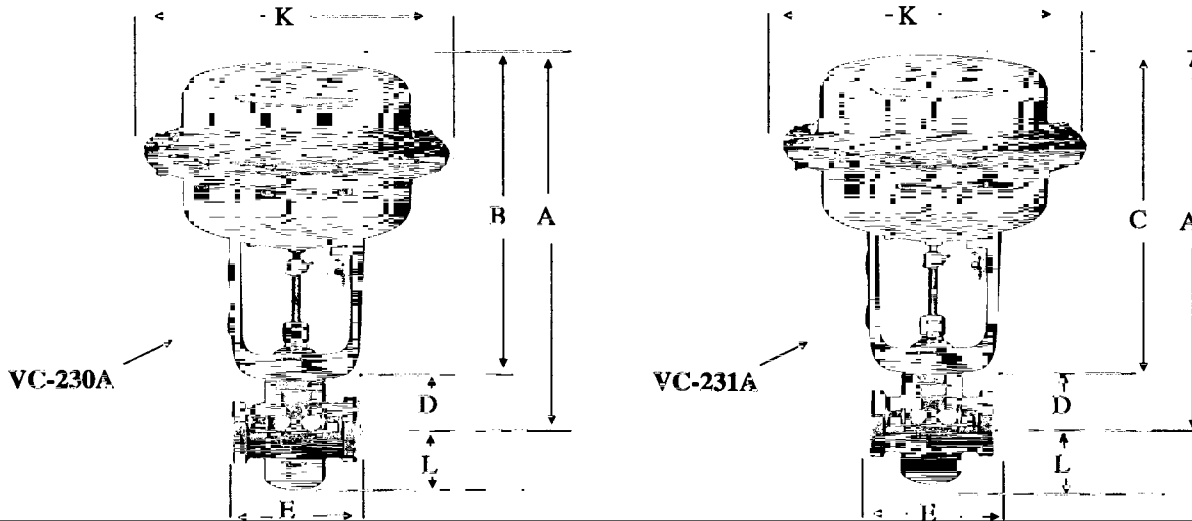

## DIMENSIONS

All dimensions in inches (millimeters)

Dim.	Valve Size In.	VALVE STYLES								
		BC	BG	MA	MAS	FA		WA	WD	WE
						Direct Acting	Reverse Acting			
D	1/2		1-15/16 (49.2)					1-9/16 (39.7)		1-13/16 (46.0)
	3/4		1-15/16 (49.2)	3-7/16 (87.3)	3-7/16 (87.3)	2-1/16 (52.4)	2-1/16 (52.4)	1-7/8 (47.6)		1-15/16 (49.2)
	1	2-3/4 (69.9)	2-3/4 (69.9)	3-7/16 (87.3)	3-7/16 (87.3)	2-13/16 (71.4)	2-13/16 (71.4)	1-7/8 (47.6)		2-3/4 (69.9)
	1 1/4	2-3/4 (69.9)	2-3/4 (69.9)	3-5/8 (92.1)		2-13/16 (71.4)	2-13/16 (71.4)	2-11/16 (68.3)		2-3/4 (69.9)
	1 1/2	2-3/4 (69.9)	2-3/4 (69.9)	4-1/8 (105)	4-1/8 (105)	3-1/8 (79.4)	3-1/8 (79.4)	3-1/16 (77.8)		2-7/8 (73.0)
	2	2-13/16 (71.4)		4-15/16 (125)	5 (127)	3-13/16 (96.8)	3-1/8 (79.4)		4-3/16 (106)	2-7/8 (73.0)
	2 1/2					4-3/8 (111)	3-5/8 (92.1)		4 (102)	
	3					4-3/4 (121)	3-15/16 (100)		4 (102)	
	4					5-13/16 (148)	5 (127)		3-9/16 (90.5)	
5								6 (152)		
6								6 (152)		
E	1/2		3 (76.2)					4-3/4 (121)		3 (76.2)
	3/4		4 (102)	6-15/16 (176)	5-3/4 (146)	5-5/8 (143)	5-5/8 (143)	6-13/16 (157)		4 (102)
	1	5 (127)	5 (127)	7-1/8 (181)	5-3/4 (146)	7-1/4 (184)	7-1/4 (184)	6-1/4 (159)		5 (127)
	1 1/4	5-1/8 (130)	5 (127)	7-1/2 (191)		7-13/16 (198)	7-13/16 (198)	7-13/16 (198)		5 (127)
	1 1/2	5-1/8 (130)	5 (127)	8-1/2 (216)	8-13/16 (224)*	8-1/2 (216)	8-1/2 (216)	8-11/16 (221)		5-1/8 (130)
	2	6-3/4 (171)		7 (178)	10-1/2 (267)	7 (178)	7 (178)		8-5/8 (219)	6-3/4 (171)
	2 1/2					7-3/4 (197)	7-3/4 (197)		10 (254)	
	3					8-5/8 (219)	8-5/8 (219)		10-1/2 (267)	
	4					10-1/4 (260)	10-1/4 (260)		15-7/8 (403)	
5								19-1/4 (489)		
6								23-1/2 (597)		
L	1/2		1-11/16 (42.9)					2-1/8 (54.0)		1-5/16 (33.3)
	3/4		2 (50.8)	1-1/2 (38.1)	1-1/2 (38.1)	2-5/16 (58.7)	2-5/16 (58.7)	2-7/16 (61.9)		2-1/4 (57.2)
	1	1-7/8 (47.6)	2-15/16 (74.6)	1-1/2 (38.1)	1 1/2 (38.1)	3-1/16 (77.8)	3-1/16 (77.8)	2-7/16 (61.9)		3-1/2 (88.9)
	1 1/4	1-7/8 (47.6)	2-15/16 (74.6)	1-7/8 (47.6)		3-1/16 (77.8)	3-1/16 (77.8)	3-1/4 (82.6)		3-1/2 (88.9)
	1 1/2	1-7/8 (47.6)	2-15/16 (74.6)	1-15/16 (49.2)	1-15/16 (49.2)	3-3/8 (85.7)	3-3/8 (85.7)	3-3/4 (95.3)		3-3/8 (85.7)
	2	2-1/8 (54.0)		2-3/4 (69.9)	2-3/4 (69.9)	3-1/8 (79.4)	3-13/16 (96.8)		5-3/16 (132)	3-3/4 (95.3)
	2 1/2					3-5/8 (92.1)	4-3/8 (111)		6-1/2 (165)	
	3					3-15/16 (100)	4-3/4 (121)		6-3/4 (171)	
	4					5 (127)	5-13/16 (148)		8-9/16 (217)	
5								11-5/8 (295)		
6								13-7/16 (341)		
K	All	9.5 (241)	9.5 (241)	9.5 (241)	9.5 (241)	9.5 (241)	9.5 (241)	9.5 (241)	9.5 (241)	9.5 (241)
A	All	Add dimensions B and D for VC-230A, and add dimensions C and D for VC-231A								
B	All	9-3/8 (238) for VC-230A								
C	All	10-7/8 (276) for VC-231A								

\* 9-1/4" (235 mm) on 300 lb. flanged body.



**Robertshaw Industrial Products**  
**1602 Mustang Drive**  
**Maryville, Tennessee 37801**  
**Phone: (865) 981-3100 Fax: (865) 981-3168**  
**<http://www.robertshawindustrial.com>**