

TZIDC Electro-Pneumatic Positioner

Compact, well-proven, and flexible



HART protocol

For 4 ... 20 mA two-wire technology

Low operating cost

Compact design

Well-proven technology

Robust and environmentally ruggedized

Wide operating temperature range

— -40 ... 85 °C (-40 ... 185 °F)

Easy to commission, “single pushbutton” operating philosophy

Mechanical position indicator

ATEX, FM, CSA, GOST and IECEx approvals

For SIL2 safety loops

Contents

1	Description	3
1.1	Pneumatics.....	3
1.2	Operation.....	3
1.3	Communication	3
1.4	Inputs and outputs.....	3
1.5	Modular design.....	3
2	Mounting versions	5
2.1	To linear actuators in accordance with the standard	5
2.2	To rotary actuators in accordance with the standard	5
2.3	Integral mounting to control valves	5
2.4	Special actuator-specific mounting	5
3	Operation	7
3.1	General.....	7
3.2	Operator panel	8
4	Communication	9
4.1	DTM.....	9
4.2	LKS adapter (RS-232 interface converter).....	9
4.3	FSK Modem	9
5	Specifications	10
5.1	Input.....	10
5.2	Output.....	10
5.3	Travel.....	10
5.4	Air supply.....	10
5.5	Transmission data and influences.....	10
5.6	Environmental capabilities	11
5.7	Housing	11
5.8	Safety Integrity Level.....	11
5.9	Explosion protection	11
5.10	Options	12
5.11	Accessories	13
6	Ex relevant specifications	14
6.1	ATEX	14
6.2	IECEX	15
7	Electrical connections	17
7.1	TZIDC with remote sensor	18
7.2	TZIDC for external remote sensor.....	19
8	Dimensions	20
9	Ordering information	23
9.1	Accessories	25

1 Description

The TZIDC is an electronically configurable positioner with communication capabilities designed for mounting to pneumatic linear or rotary actuators. It features a small and compact design, a modular construction, and an excellent cost-performance ratio.

Fully automatic determination of the control parameters and adaptation to the final control element yield considerable time savings and an optimal control behavior.

1.1 Pneumatics

An I/P module with subsequent pneumatic amplifier is used to control the pneumatic actuator. The well-proven I/P module proportionally converts the permanent electrical setpoint signal from the CPU into a pneumatic signal used to adjust a 3/3-way valve.

The air flow for pressurizing or depressurizing the actuator is continuously adjusted. As a result, excellent control is achieved. When reaching the set point, the 3/3-way valve is closed in center position to minimize the air consumption.

Four different pneumatics versions are available: for single-acting or double-acting actuators, each with "fail-safe" or "fail-freeze" function.

1.1.1 "Fail-safe" function

If the electrical power supply fails, the positioner output 1 is depressurized, and the pneumatic actuator's return spring moves the valve to the defined safe position. In case of a double-acting actuator the second output 2 is additionally pressurized.

1.1.2 "Fail-freeze" function

If the electrical power supply should fail, the positioner output 1 (and 2, if applicable) is closed and the pneumatic actuator stops ("freezes") the valve in the current position. If compressed air supply should fail, the positioner depressurizes the actuator.

1.2 Operation

The positioner has a built-in operating panel providing a 2-line LCD and 4 pushbuttons for optimal local configuration, commissioning and operational monitoring.

Alternatively, the appropriate configuration program and the available communication option can be used.

1.3 Communication

The standard TZIDC model has a local communication interface (LKS connector). Additionally, a "HART communication" option for communication via the 20 mA signal is available. Both communications are based on the HART Protocol.

1.4 Inputs and outputs

In addition to its input for the analog position set point the TZIDC positioner is equipped with a digital input which can be used to activate various protective functions in the device via the process control system. A digital output allows you to output collective alarms or fault messages.

1.5 Modular design

The TZIDC basic model can be enhanced at any time by retrofitting optional equipment. Option modules for analog or digital position feedback or a shutdown-module can be installed. Additionally, a mechanical position indicator, proximity switches or 24 V microswitches are available for indicating the position independently of the mother board function.

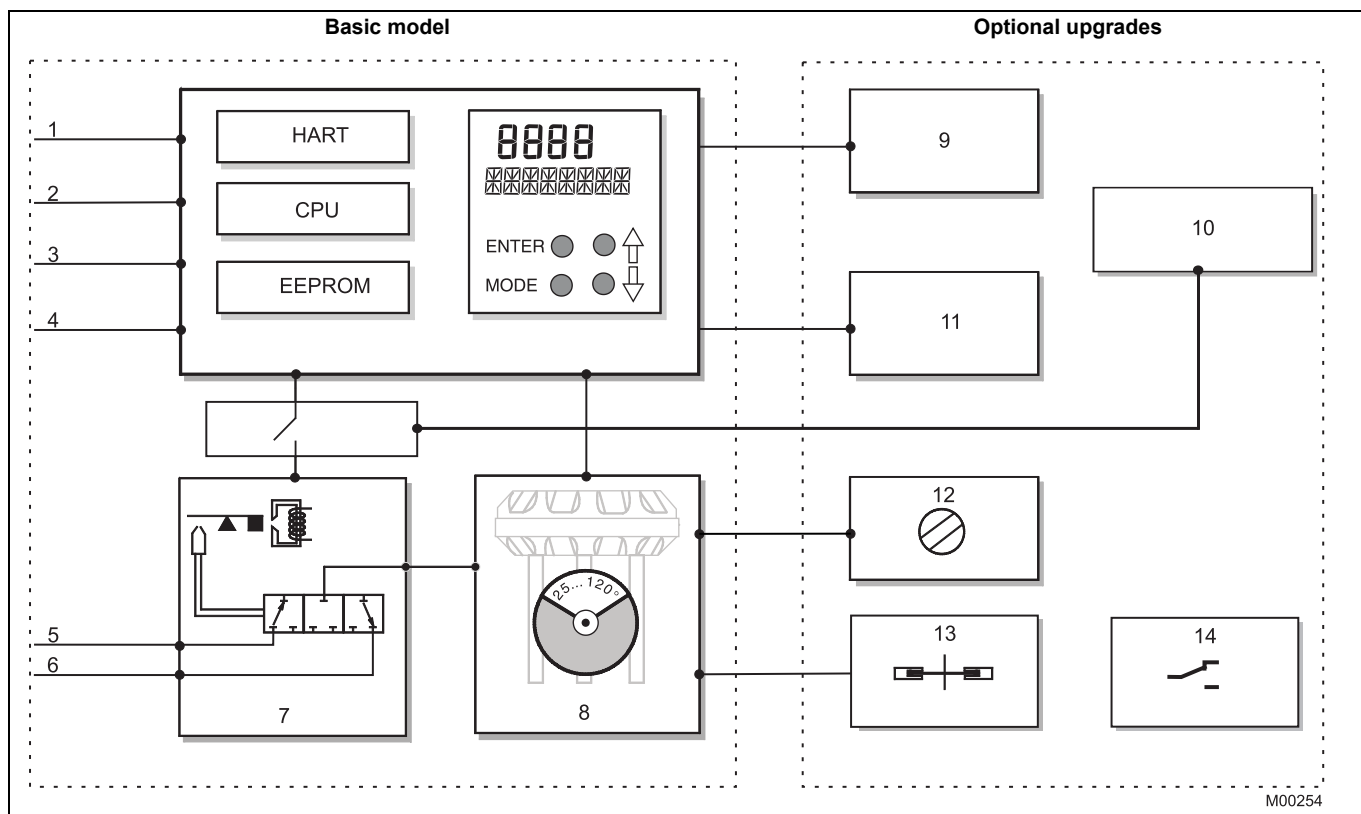

Fig. 1: TZIDC schematic diagram

Basic model

- 1 LKS plug
- 2 Setpoint signal 4 ... 20 mA
- 3 Digital input
- 4 Digital output DO
- 5 Supply, 1.4 ... 6 bar (20 ... 90 psi)
- 6 Exhaust
- 7 I/P module with 3/3-way valve
- 8 Position sensor (optional up to 270° rotation angle)

Optional upgrades

- 9 Plug module for analog feedback (4 ... 20 mA)
- 10 Plug-in module for safety shutdown (forced depressurization)
- 11 Plug module for digital feedback
- 12 Installation kit for mechanical position indicator
- 13 Installation kit for digital feedback with proximity switches
- 14 Installation kit for digital feedback with 24 V microswitches



IMPORTANT (NOTE)

With optional upgrades either the "Installation kit for digital feedback with proximity switches" (13) or the "Installation kit for digital feedback with microswitches 24 V" (14) can be used.

In both cases, the "mechanical position indicator" (8) must be installed.

2 Mounting versions

2.1 To linear actuators in accordance with the standard

Lateral attachment is in accordance with DIN / IEC 534 (lateral attachment to NAMUR). The required attachment kit is a complete set of attachment material, but does not include the screwed pipe connections and air pipes.

2.2 To rotary actuators in accordance with the standard

This attachment is designed for mounting according to the standard VDI/VDE 3845. The attachment kit consists of a console with mounting screws for mounting on a rotary actuator. The adapter for coupling the positioner feedback shaft to the actuator shaft has to be ordered separately. Screwed pipe connections and air pipes have to be provided on site.

2.3 Integral mounting to control valves

The TZIDC positioner featuring standard pneumatic action is available as an option for integral mounting.

The required holes are found at the back of the device.

The benefit of this design is that the point for mechanical stroke measurement is protected and that the positioner and actuator are linked internally. No external tubing is required.

2.4 Special actuator-specific mounting

In addition to the mounting methods described above, there are special actuator-specific attachments.

Please contact us for details.

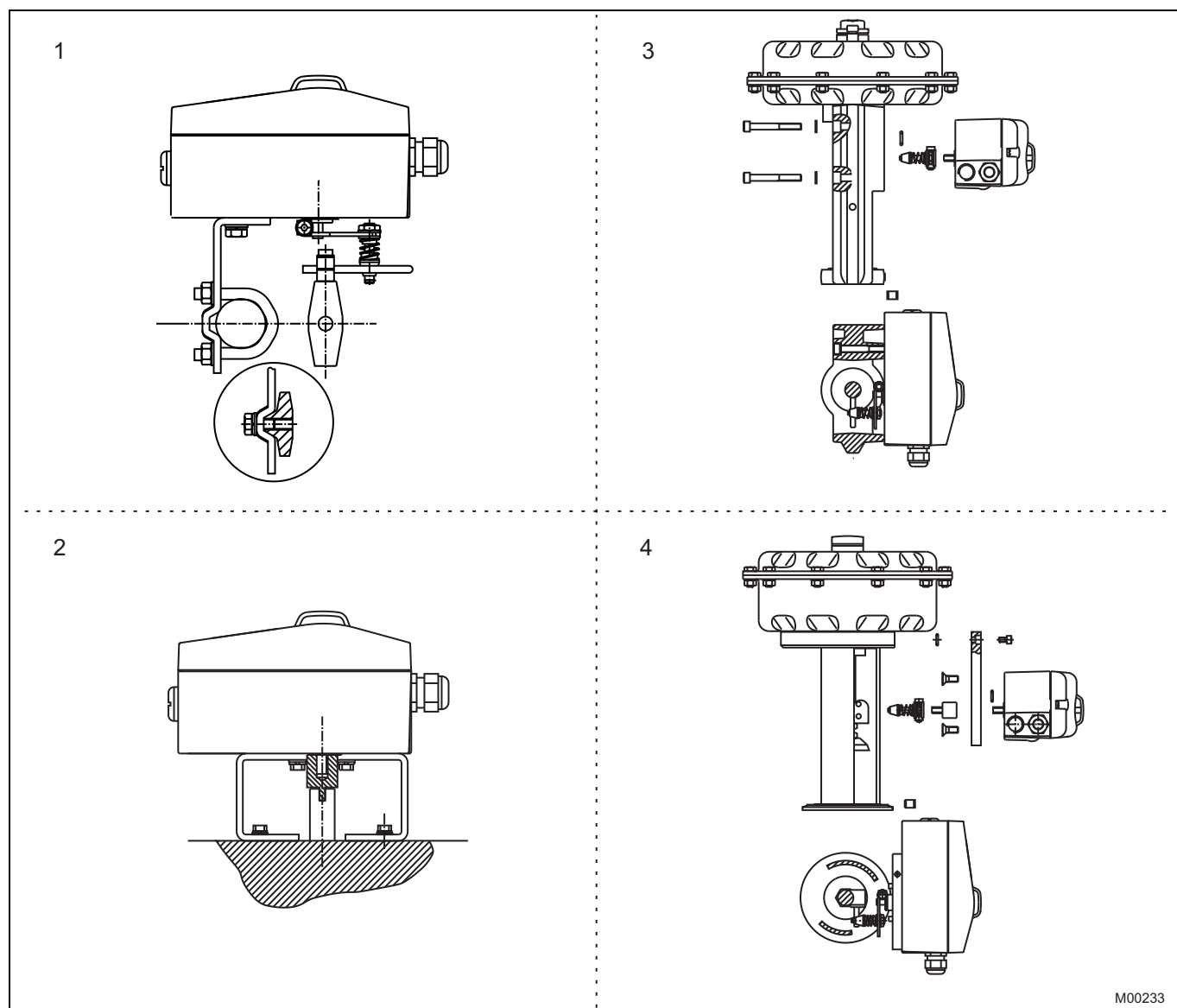

M00233

Fig. 2: Mounting options

- 1 Mounting to linear actuators acc. to DIN / IEC 534
- 2 Mounting to rotary actuators to VDI / VDE 3845

- 3 Integral mounting to control valves
- 4 Integral mounting to control valves by using an adapter panel

3 Operation

3.1 General

Microprocessor-based position control in the TZIDC provides for optimal results. The positioner features high-precision control functions and high operational reliability. Due to their elaborate structure and easy accessibility, the device parameters can be quickly adapted to the respective application.

The total range of parameters includes:

- Operating parameters
- Adjustment parameters
- Monitoring parameters
- Diagnosis parameters
- Maintenance parameters

3.1.1 Operating parameters

The following operating parameters can be set manually if required:

Setpoint Signal

Signal min. 4 mA, max. signal 20 mA (0 ... 100 %)
freely selectable for split-range operation
min. range 20 % (3.2 mA)
recommended range > 50 % (8.0 mA)

Action (setpoint signal)

Increasing: Setpoint Signal 4 ... 20 mA = position 0 ... 100 %
Decreasing: Setpoint Signal 20 ... 4 mA = position 0 ... 100 %

Characteristic curve (travel = f {setpoint signal})

Linear, equal percentage 1:25 or 1:50 or 25:1 or 50:1 or freely configurable with 20 reference points.

Travel limit

The positioning travel, i.e. the stroke or angle of rotation, can be reduced as required within the full range of 0 ... 100 %, provided that a minimum value of 20 % is observed.

Shut-off function

This parameter can be set separately for each end position. When the respective configured limit value is exceeded, the shut-off function causes immediate travel of the actuator until reaching the set end position.

When the shut-off value is set to "0", the position is further controlled, even in the respective end position.

Travel time prolongation

This function can be used to increase the max. travel time for full travel. This time parameter can be set separately for each direction.



IMPORTANT (NOTE)

This function can only be used with the pneumatics with the safety function "fail-safe".

Switching points for the position

This parameter allows you to define two position limits for signaling (see option "Module for digital position feedback").

Digital output

The alarms generated in the TZIDC positioner can be polled via the digital output as a collective alarm.

The desired information can be selected via the operator panel or remotely via the configuration program.

The output can be set to "active high" or "active low", as required.

Digital input

For the digital input, one of the following safety options can be selected. You may use the operator's panel or configuration program to select an option.

- No function (default)
- Move to 0 % position
- Move to 100 % position
- Hold previous position
- disable local configuration
- Disable local configuration and operation
- Disable any access (no local or remote access via a PC)

The selected function is activated once the 24 V DC signal is no longer applied (< 11 V DC).

3.1.2 Adjustment parameters

The TZIDC positioner has a special function for automatic adjustment of the parameters.

Additionally, the control parameters can be set automatically (in adaptive control mode) or manually to optimally adapt them to the process requirements.

Tolerance band

Upon reaching the tolerance band, the position is slowly re-adjusted until the dead band has been reached.

Dead band (sensitivity)

When reaching the dead band, the position is held. The factory setting for this parameter is 0,1 %.

Actuator spring action

Selection of the sensor shaft rotating sense (looking into the open case), if the valve is moved to the safe position by the actuator spring (actuator is depressurized via Y1 / OUT1).

For double-acting actuators the actuator spring action corresponds to pressurizing the pneumatic output (OUT2).

Display 0 ... 100 %

Adjusting the display (0 ... 100%) according to the direction of action for opening or closing the valve.

3.1.3 Monitoring parameters

Various functions for permanent operational monitoring are implemented in the TZIDC operating program. The following states will be detected and indicated, e.g.:

- 4 ... 20 mA setpoint signal out of range
- position out of the adjusted range
- positioning time-out (adjustable time parameter)
- position controller inactive
- counter limits (settable in the diagnosis phase) exceeded

While automatic commissioning is in progress, the current state is continuously indicated on the integrated LCD.

During operation, the LCD shows the most important process variables:

- current position (in %),
- malfunctions, alarms, messages (as code)

Access to extended monitoring parameters is possible via HART communication and the DTM.

3.1.4 Diagnosis parameters

The diagnosis parameters of the TZIDC program inform the operator about the operating conditions of the valve.

From this information the operator can derive which maintenance works are required, and when.

Additionally, limit values can be defined for these parameters. When they are exceeded, an alarm is reported.

The following values are e.g. determined:

- Number of movements performed by the valve
- Total travel

The diagnosis parameters and limit values can be called up, set, and reset via HART communication, using the configuration program.

3.2 Operator panel

The TZIDC positioner's operator panel with four pushbuttons allows for

- operational monitoring
- manual control
- configuration
- fully automatic commissioning

The operator panel is protected by a cover which avoids unauthorized access to the operating elements.

3.2.1 Single-button commissioning

Commissioning the TZIDC positioner is especially easy. The standard Autoadjust function for automatic adaptation of the device parameters can be started by simply pressing a single front panel button, and without knowing parameterization details.

Depending on the selected actuator type (linear or rotary), the displayed zero position is automatically adapted:

- for linear actuators counter-clockwise (CTCLOCKW)
- for rotary actuators clockwise (CLOCKW).

Besides this standard function, a customized "Autoadjust" function is available. The function is launched either via the operator's panel or HART communication.

3.2.2 Display

The information indicated by the 2-line LC display is permanently updated and adapted during operation, to inform the operator in an optimal way.

During control operation (control with or without adaptation) the following TZIDC data can be called up by pressing the pushbuttons briefly:

- Up button: Current setpoint (mA)
- Down button: Temperature in device
- Up + Down buttons: Current control deviation



Fig. 3: TZIDC with removed cover, view of the operator panel

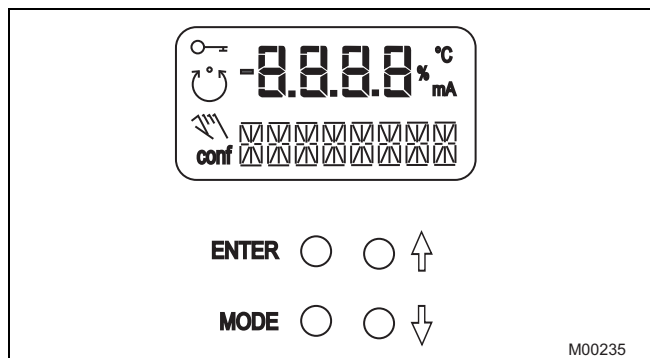

Fig. 4: TZIDC operating elements and display

4 Communication

4.1 DTM

The DTM (Device Type Manager) for TZIDC is based on the FDT / DTM technology (FDT 1.2) and can be integrated in a process control system or loaded in a PC with the DSV401 (SMART VISION) program. This allows you to work with the same user interface in the commissioning phase, during operation, and for service tasks for monitoring the device, setting parameters, and uploading data.

Communication is based on the HART protocol. It occurs via a local interface connection (LKS) or in frequency-modulated mode using an FSK-modem connected at any chosen point of the 20 mA signal line. Communication has no effect on operation. Newly set parameters are saved in the non-volatile memory directly upon the download into the device, and become active immediately.

4.2 LKS adapter (RS-232 interface converter)

You can easily connect your TZIDC positioner to a PC, e.g., in the workshop or in the commissioning phase, by using the positioner's LKS adapter (LKS = local communication interface).

An RS-232 interface converter adapts the signals on the serial PC port to the level of the positioner's LKS.

4.3 FSK Modem

The FSK modem establishes a digital frequency-modulated communication (Frequency Shift Keying) with the TZIDC positioner.

Tapping is possible at any chosen point of the 20 mA signal line.

We recommend that you use an electrically isolated FSK modem. It is bus-compatible when used with isolating amplifiers. Even connecting explosion-protected field devices is possible, on condition that the FSK modem is run outside the hazardous area.

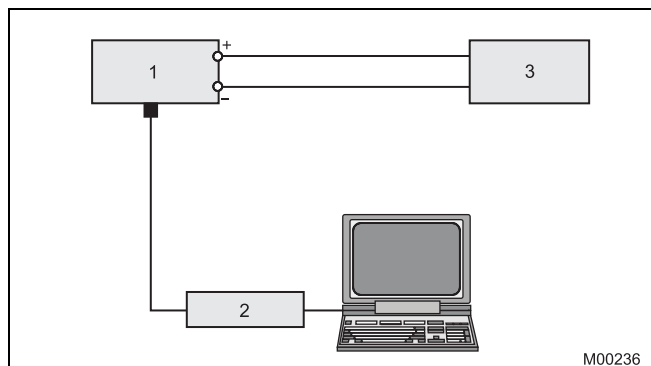

Fig. 5: Local communication via LKS adapter
1 TZIDC 3 Controller
2 LKS adapter

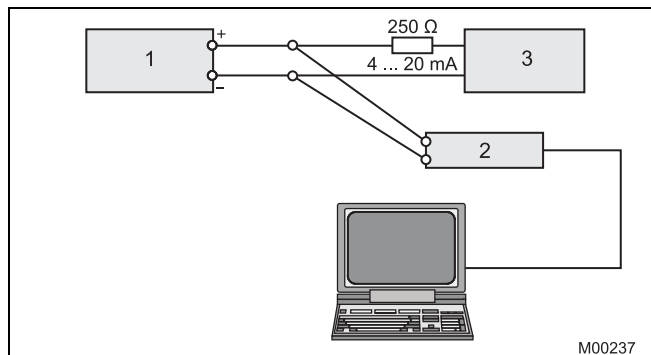

Fig. 6: HART communication with FSK modem via 20 mA signal line
1 TZIDC 3 Controller
2 FSK modem

5 Specifications

5.1 Input

Setpoint signal (two-wire technology)

Nominal range	4 ... 20 mA
Split range configuration between	20 ... 100 % of the nominal range
Max.	50 mA
Min.	3.6 mA
Starting at	3.8 mA
Load voltage at 20 mA	9.7 V
Impedance at 20 mA	485 Ω

Digital input

Control voltage	0 ... 5 V DC logical switching state "0" 11 ... 30 V DC logical switching state "1"
Current	max. 4 mA

5.2 Output

Compressed air output

Range	0 ... 6 bar (0 ... 90 psi)
Air capacity	5.0 kg/h = 3.9 Nm ³ /h = 2.3 scfm at 1.4 bar (20 psi) supply pressure 13 kg/h = 10 Nm ³ /h = 6.0 scfm at 6 bar (90 psi) supply pressure
Output function	For single or double-acting actuators, air is vented from actuator or actuator is blocked in case of (electrical) power failure
Shut-off values	End position 0 % = 0 ... 45 % End position 100 % = 55 ... 100 %

Digital output (control circuit to DIN 19234 / NAMUR)

Supply voltage	5 ... 11 V DC
Current > 0.35 mA ... < 1.2 mA	Switching state logical "0"
Current > 2.1 mA	Switching state logical "1"
Effective direction (configurable)	normally logical "0" or logical "1"

5.3 Travel

Rotation angle

Used range	25 ... 120° (rotary actuators, optional 270°) 25 ... 60° (linear actuators)
Travel limit	Min. and max. limits, freely configurable between 0 ... 100 % of total travel (min. range > 20 %)
Travel time prolongation	Range of 0 ... 200 s, separately for each direction
Dead band time limit	Setting range 0 ... 200 s (monitoring parameter for control until the deviation reaches the dead band)

5.4 Air supply

Instrument air

free of oil, water and dust to DIN/ISO 8573-1. Pollution and oil content according to Class 3 (purity: max. particle size = 5 μm, max. particle density = 5 mg / m³; oil content: max. concentration = 1 mg / m³; pressure dew point: 10 K below operating temperature)

Supply pressure

1.4 ... 6 bar (20 ... 90 psi)

i IMPORTANT (NOTE)

Do not exceed the maximum operating pressure of the actuator!

Air consumption

< 0.03 kg/h / 0.015 scfm (independent of supply pressure)

5.5 Transmission data and influences

Output Y1

Increasing	Increasing setpoint signal 0 ... 100 % Increasing pressure at output
Decreasing	Increasing setpoint signal 0 ... 100 % Decreasing pressure at output

Action (setpoint signal)

Increasing	Signal 4 ... 20 mA = actuator position 0 ... 100 %
Decreasing	Signal 20 ... 4 mA = actuator position 0 ... 100 %

Characteristic curve (travel = f {setpoint signal})

Linear, equal percentage 1:25 or 1:50 or 25:1 or 50:1 and freely configurable with 20 reference points.

Deviation	≤ 0.5 %
Tolerance band	0.3 ... 10 %, adjustable
Dead band	0.1 ... 10 %, adjustable
Resolution (A/D conversion)	> 16000 steps
Sample rate	20 ms
Influence of ambient temperature	≤ 0.5 % per 10 K
Influence of vibration	≤ 1 % to 10 g and 80 Hz

Seismic vibration

Meets requirements of DIN / IEC 68-3-3 Class III for strong and strongest earthquakes.

Influence of mounting orientation

Not measurable.

Complies with the following directives

- EMC Directive 2004/108/EC as of December 2004
- EC Directive for CE conformity marking

Communication

- HART Protocol 5.9
- Local connector for LKS (not in Ex area)
- HART communication via 20 mA signal line with (optional) FSK modem

5.6 Environmental capabilities

Ambient temperature

For operation, storage and transport: -40 ... 85 °C (-40 ... 185 °F)
When using proximity switches SJ2-S1N (NO): -25 ... 85 °C (-13 ... 185 °F)

Relative humidity

Operational (with closed housing and air supply switched on): 95 % (annual average), condensation permissible
Transport and storage: 75 % (annual average), non-condensing

5.7 Housing

Material / Degree of protection

Aluminum with ≤ 0.1 % copper, protection class IP 65 (optional IP 66) / NEMA 4X

Surface / Color

Electrostatic dipping varnish with epoxy resin, stove-hardened.
Case varnished black, RAL 9005, matte, housing cover Pantone 420.

Electrical connections

Screw terminals: Max. 1.0 mm² (AWG 17) for options
Max. 2.5 mm² (14 AWG) for bus connector

i **IMPORTANT (NOTE)**
Do not expose the terminals to strain.

Four thread combinations for cable entry and pneumatic connection

- Cable: thread 1/2-14NPT, air pipe: thread 1/4-18 NPT
 - Cable: thread M20 x 1,5, air pipe: thread 1/4-18 NPT
 - Cable: thread M20 x 1,5, air pipe: thread G 1/4
 - Cable: thread G 1/2, air pipe: thread Rc 1/4
- (Optional: With cable gland(s) and pipe plugs if necessary)

Weight

1,7 kg (3,75 lb)

Mounting orientation

Any

5.8 Safety Integrity Level

i **IMPORTANT (NOTE)**
Applies to applications with single-acting and depressurizing pneumatics.

The positioner TZIDC / TZIDC-200 and the emergency shutdown module for meet the requirements regarding:

- functional safety acc. to IEC 61508
- explosion protection (depending on the model)
- electromagnetic compatibility in accordance with EN 61000

Without the input signal, the pneumatic module in the positioner vents the drive and the installed spring in it moves the valve in a predetermined end position (OPEN or CLOSED).

SIL specific safety-related characteristics:

Device	SFF	PFDav	$\lambda_{dd} + \lambda_s$	λ_{du}
TZIDC / TZIDC-200 as shutdown module	94 %	1.76 * 10 ⁻⁴	718 FIT	40 FIT
TZIDC / TZIDC-200 with supply current 0 mA	94 %	1.76 * 10 ⁻⁴	651 FIT	40 FIT

For details refer to the Management Summary in the SIL-Safety Instructions 37/18-79XA.

5.9 Explosion protection

i **IMPORTANT (NOTE)**
The values indicated here are taken from the respective approval certificates.

Always observe the specifications and supplements in the certificates.
(see operating instructions).

FM J.I. 3005029 (3610, 3611)

Intrinsic safety
Class I, Div. 1 Grp. A-B-C-D
Class II, Div. 1 Grp. E-F-G
CL III, Div. 1
Non-Incendive, suitable for use in Div. 2 environment

CSA Certification 1052414

Intrinsically Safe; Enclosure 4X; T4, max. 85 °C
Class I, Div. 1 Grp. A-B-C-D
Class II, Div. 1 Grp. E-F-G
CL III, Div. 1

Non-Incendive; Enclosure 4X, max. 85 °C
Class I, Div. 2 Grp. A-B-C-D
Class II, Div. 2 Grp. E-F-G
CL III

5.10 Options

Module for analog position feedback ¹⁾

Signal range	4 ... 20 mA (configurable split ranges)
Supply, 2-wire circuitry	24 V DC (10 ... 30 V DC) 48 V DC (20 ... 48 V DC, no ignition protection)
Characteristic curve (configurable)	Rising or falling
Deviation	< 1 %

i IMPORTANT (NOTE)

Without a signal from the positioner (e.g., "no power" or "initializing") the module sets the output to > 20 mA (alarm level)

Module for digital position feedback ¹⁾

Two switches for digital position feedback (position adjustable within the range of 0 ... 100 %, ranges cannot overlap)

Current circuits acc. to DIN 19234 / NAMUR

Supply voltage	5 ... 11 V DC
Signal current < 1.2 mA	Switching state logical "0"
Signal current > 2.1 mA	Switching state logical "1"
Direction of action	normally logical "0" or logical "1" (configurable)

Module for the emergency shutdown function ²⁾

Supply voltage	24 V DC (20 ... 30 V DC) (galvanically isolated from input signal)
Safe position is activated when	Voltage < 5 V
SIL	See "Safety Integrity Level"

A separate 24 V DC signal is normally applied to the emergency shutdown module, which connects through the signal from the microprocessor to the I/P module.

When the 24 V DC signal is interrupted, the I/P module executes the respective safety function, depending on the mechanical construction.

The positioner output 1 is depressurized, and the valve is moved to the safe position. In case of a double-acting actuator the second output 2 is additionally pressurized.

i IMPORTANT (NOTE)

The emergency shutdown module can only be used with pneumatics with the safe position "fail-safe".

The emergency shutdown module works independently of the mother board, i.e. all information from the final control element is available in the supervisory process control system at any time.

- 1) The module for analog position feedback and the module for digital position feedback plug in separate slots and can be used together.
- 2) The module for the emergency shutdown function uses the same space as the module for analog feedback and the module for analog or digital feedback and cannot be plugged in and run together with any of them.

Digital position feedback with proximity switches

Two proximity switches for independent position signaling, Switching points adjustable between 0 ... 100 %

Current circuits acc. to DIN 19234 / NAMUR

Supply voltage	5 ... 11 V DC
Signal current < 1.2 mA	Switching state logical "0"
Signal current > 2.1 mA	Switching state logical "1"

Direction of action (logical state)

Proximity switch	Position			
	< Lim. 1	> Lim. 1	< Lim. 2	> Lim. 2
SJ2-SN (NC)	0	1	1	0
SJ2-S1N (NO)	1	0	0	1

i IMPORTANT (NOTE)

When using proximity switch SJ2_S1N (NO), the TZIDC positioner may only be used at an ambient temperature range -25 ... 85 °C (-13 ... 185 °F).

Digital position feedback with 24 V microswitches

Two microswitches for independent position signaling. Switching points can be adjusted from 0 ... 100 %.

Voltage	max. 24 V AC / DC
Load rating	max. 2 A
Contact surface	10 µm Gold (AU)

Mechanical position indicator

Indicator disk in enclosure cover linked with positioner feedback shaft.

i IMPORTANT (NOTE)

These options are also available for retrofitting by Service.

5.11 Accessories

Mounting material

- Attachment kit for linear actuators to DIN/IEC 534 / NAMUR
- Attachment kit for part-turn actuators to VDI / VDE 3845
- Attachment kit for integral mounting to control valves
- Attachment kit for actuator-specific attachment upon request

Pressure gauge block

- With pressure gauges for supply and output pressure.
- Pressure gauges with housing \varnothing 28 mm
- Aluminum connection block in black
- Installation material in black for mounting to TZIDC

Filter regulator

All metal version in brass, varnished black, bronze filter element, (40 μ m) , with condensate drain.

max. pre-pressure 16 bar (232 psi), output adjustable to 1.4 ... 6 bar (20 ... 90 psi).

i IMPORTANT (NOTE)

The filter regulator may only be installed in combination with the pressure gauge block (accessory).

PC adapter for communication

LKS adapter for plug-in connection to TZIDC

FSK modem for HART communication

PC software for remote configuration and operation

DAT200 Asset Vision Basic with DTM for TZIDC on CD-ROM

6 Ex relevant specifications

6.1 ATEX

Designation:	II 2 G Ex ia IIC T6 resp. T4 Gb II 2 G Ex ib IIC T6 resp. T4 Gb II 2 D Ex ia IIIC T51°C resp. 70°C Db
Type-Examination Test Certificate:	TÜV 04 ATEX 2702 X
Type:	Intrinsically safe equipment
Device class:	II 2 G
Standards:	EN 60079-0:2009 EN 60079-11:2007
Device class:	II 2D
Standards:	EN 60079-0:2009 EN 61241-11:2006

II 2 G Temperature class	Ta Ambient temperature range
T4	-40 ... 85 °C
T5	-40 ... 50 °C
T6 1)	-40 ... 40 °C

1) When using the "digital feedback" plug-in module in temperature class T6, the maximum permissible ambient temperature range is -40 ... 35 °C.

II 2 D Housing surface temperature	Ta Ambient temperature range (II 2 D)
T81 °C	-40 ... 70 °C
T61 °C	-40 ... 50 °C
T51 °C	-40 ... 40 °C

Electrical data

	In intrinsically safe explosion protection types Ex ib IIC / Ex ia IIC or Ex iaD, only for connection to a certified intrinsically safe circuit
Signal circuit (Terminal +11 / -12)	Maximum values: U _i = 30 V I _i = 320 mA P _i = 1.1 W C _i = 6.6 nF L _i negligibly small
Contact input (Terminal +81 / -82)	Maximum values: U _i = 30 V I _i = 320 mA P _i = 1.1 W C _i = 4.2 nF L _i negligibly small
Switch output (Terminal +83 / -84)	Maximum values: U _i = 30 V I _i = 320 mA P _i = 500 mW C _i = 4.2 nF L _i negligibly small
Mechanical digital feedback (Terminals Limit1 +51 / -52 or Limit2 +41 / -42)	For max. values, see EC-type-examination test certificate number PTB 00 ATEX 2049 X Proximity switches manuf. by Pepperl & Fuchs
Plug-in module for digital position feedback (Terminal +51 / -52) or +41 / -42)	Maximum values: U _i = 30 V I _i = 320 mA P _i = 500 mW C _i = 3.7 nF L _i negligibly small
Plug-in module for analog position feedback (Terminal +31 / -32)	Maximum values: U _i = 30 V I _i = 320 mA P _i = 1.1 W C _i = 6.6 nF L _i negligibly small
Plug-in module for shutdown contact input (Terminal +51 / -52) or +85 / -86)	U _i = 30 V I _i = 320 mA P _i = 1.1 W C _i = 3.7 nF L _i negligibly small
Local communication interface (LKS)	Only for connection to a programmer outside the potentially explosive area.

Designation: II 3 G Ex nA IIC T6 resp. T4 Gc
 Declaration of conformity: TÜV 02 ATEX 1943 X
 Type: Type of protection "n"
 Device class: II 3 G
 Standards: EN 60079-15:2010
 EN 60079-0:2009

II 3 G Temperature class	Ta Ambient temperature range
T4	-40 ... 85 °C
T5	-40 ... 65 °C
T6	-40 ... 50 °C

Electrical data

Signal circuit (Terminal +11 / -12)	$U_i = 9.7 \text{ V DC}$ $I = 4 \dots 20 \text{ mA, max. } 21.5 \text{ mA}$
Contact input (Terminal +81 / -82)	$U = 12 \dots 24 \text{ V DC; } 4 \text{ mA}$
Switch output (Terminal +83 / -84)	$U = 11 \text{ V DC}$
Mechanical digital feedback (Terminals Limit1 +51 / -52 or Limit2 +41 / -42)	$U = 5 \dots 11 \text{ V DC}$
Plug-in module for digital position feedback (Terminal +51 / -52) or +41 / -42)	$U = 5 \dots 11 \text{ V DC}$
Plug-in module for analog position feedback (Terminal +31 / -32)	$U = 10 \dots 30 \text{ V DC}$ $I = 4 \dots 20 \text{ mA, max. } 21.5 \text{ mA}$
Plug-in module for shutdown contact input (Terminal +51 / -52) or +85 / -86)	$U = 20 \dots 30 \text{ V DC}$

6.2 IECEx

Marking: Ex ia IIC Gb
 Ex nA II Gc
 Certificate No.: IECEx TUN 04.0015X
 Issue No.: 5
 Typ: Intrinsic safety "i", or Type of
 protection "n"
 Standards: IEC 60079-0:2011
 IEC 60079-11:2011
 IEC 60079-15:2010

Type and marking	TZIDC Ex i IIC Gb	TZIDC Ex nA IIC Gc
Temperature Class	Ambient temperature range	
T4	-40 ... 85 °C	-40 ... 85 °C
T5	-40 ... 50 °C	-40 ... 65 °C
T6 ¹⁾	-40 ... 40 °C	-40 ... 50 °C

1) When using the "digital feedback" plug-in module in temperature class T6, the maximum permissible ambient temperature range is -40 ... 35 °C.

Electrical data for type TZIDC with marking Ex ia IIC resp. Ex ib IIC

	In type of protection "Intrinsic Safety" Ex i IIC only for the connection to a certified intrinsically safe circuit with the following maximum values:
Signal circuit (Terminals +11 / -12)	$U_i = 30 \text{ V}$ $I_i = 320 \text{ mA}$ $P_i = 1.1 \text{ W}$ effective internal capacitance: $C_i = 6.6 \text{ nF}$ The effective internal inductance is negligibly small.
Switch input (Terminals +81 / -82)	$U_i = 30 \text{ V}$ $I_i = 320 \text{ mA}$ $P_i = 1.1 \text{ W}$ effective internal capacitance: $C_i = 4.2 \text{ nF}$ The effective internal inductance is negligibly small.
Switch output (Terminals +83 / -84)	$U_i = 30 \text{ V}$ $I_i = 320 \text{ mA}$ $P_i = 500 \text{ mW}$ effective internal capacitance: $C_i = 4.2 \text{ nF}$ The effective internal inductance is negligibly small.
Local interface for communication (LKS)	For the connection to a programmer outside of the explosiv hazardous area only. (see special conditions below)

Optionally the following modules are allowed to be used:

	In type of protection "Intrinsic Safety" (Ex ia IIC resp. Ex ib IIC) only for the connection to a certified intrinsically safe circuit with the following maximum values:
Plug-In module for digital feedback (Terminals +51 / -52 resp. +41 / -42)	U _i = 30 V I _i = 320 mA P _i = 500 mW effective internal capacitance: C _i = 3.7 nF The effective internal inductance is negligibly small.
Plug-In module for analogue feedback (Terminals +31 / -32)	U _i = 30 V I _i = 320 mA P _i = 1.1 W effective internal capacitance: C _i = 6.6 nF The effective internal inductance is negligibly small.
Plug-In module for shutdown-function (Terminals +51 / -52 resp. +85 / -86)	U _i = 30 V I _i = 320 mA P _i = 1.1 W effective internal capacitance: C _i = 3.7 nF The effective internal inductance is negligibly small.

Special conditions
The local communication interface (LKS) may only be operated at U_m ≤ 30 V DC outside the potentially explosive area.

Electrical data for type TZIDC with marking Ex nA IIC T6 resp. T4 Gc	
Signal circuit (Terminals +11 / -12)	U = 9.7 VDC; 4 ... 20 mA, max. 21.5 mA
Switch input (Terminals +81 / -82)	U = 12 ... 24 VDC; 4 mA
Switch output (Terminals +83 / -84)	U = 11 VDC

Optionally the following modules are allowed to be used with type TZIDC	
Plug-In module for digital feedback (Terminals +51 / -52 resp. +41 / -42)	U = 5 ... 11 VDC
Plug-In module for analogue feedback (Terminals +31 / -32)	U = 10 ... 30 VDC; 4 ... 20 mA, max. 21.5 mA

Additionally the following modules are allowed to be used with all types marked Ex nA IIC T6	
Plug-In module for shutdown-function (Terminals +51 / -52 resp. +85, -86)	U = 20 ... 30 VDC
Mechanical digital feedback (Terminals Limit1 +51 / -52 resp. Limit2 +41 / -42)	U = 5 ... 11 VDC

7 Electrical connections

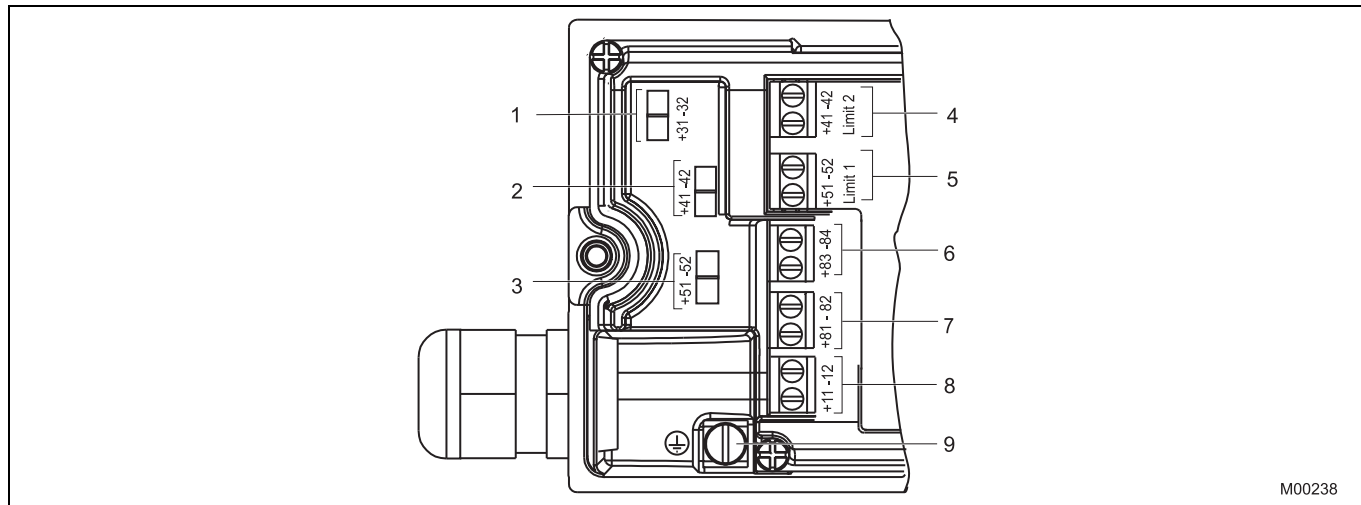

Fig. 7: Screw terminals, overview

- | | |
|--|--|
| 1 Module for analog position feedback | 5 Digital position feedback, either proximity switches or 24 V microswitches |
| 2 Module for digital feedback or service switch of emergency shutdown module | 6 Digital output DO |
| 3 Module for digital feedback or terminals for emergency shutdown module | 7 Digital input |
| 4 Digital position feedback, either proximity switches or 24 V microswitches | 8 Signal 4 ... 20 mA |
| | 9 Grounding screw |

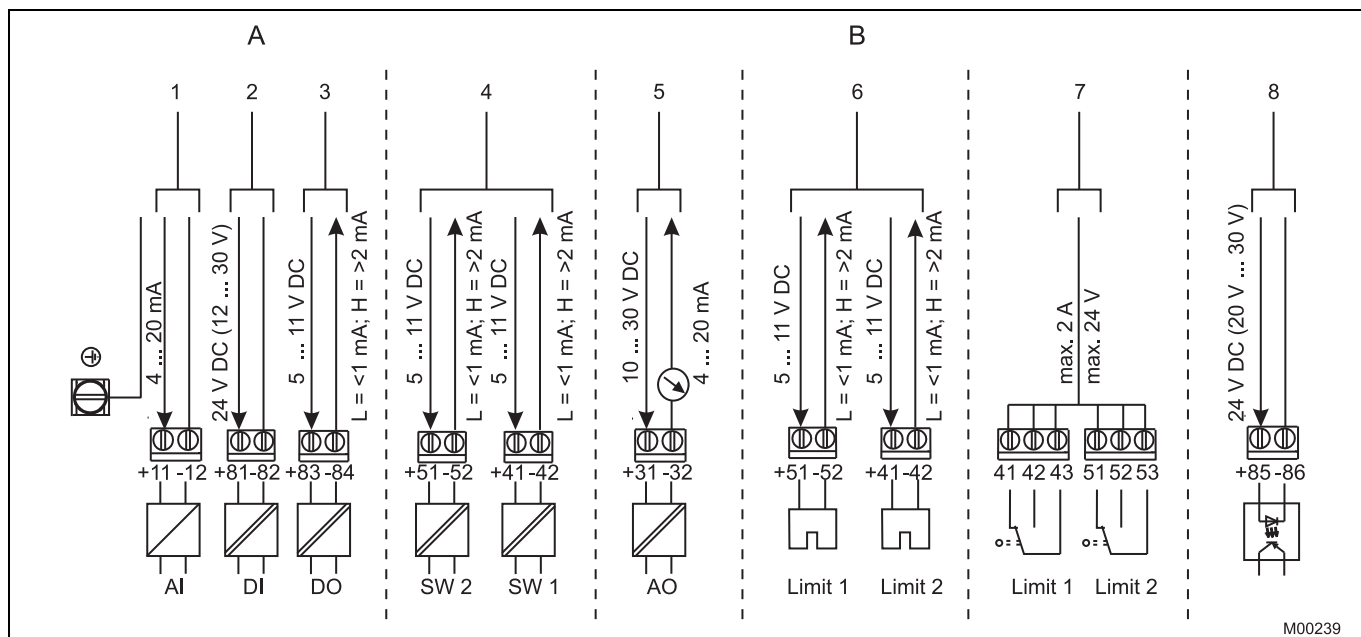

Fig. 8: Pin configuration

- | | |
|---------------|-----------------------------|
| A Basic model | 1 Analog input |
| B Options | 2 Digital input |
| | 3 Digital output DO |
| | 4 Digital feedback |
| | 5 Analog feedback |
| | 6 Proximity switches |
| | 7 Microswitches |
| | 8 Emergency shutdown module |

7.1 TZIDC with remote sensor

In the case of the "TZIDC with remote sensor" design, the components are supplied in two housings, which together form one harmonized unit.

Housing 1 (control unit) contains the electronics and pneumatics along with the following options (where applicable):

- Analog position feedback
- Digital position feedback
- Shutdown module

Housing 2 (remote sensor) contains the position sensor and is suitable for mounting on linear and part-turn actuators.

The following options can be installed if required:

- Optical position indicator
- Mechanical feedback contacts (proximity switch or microswitch design)

The two housings can be or are connected to a shielded 3-wire cable. The maximum cable length is 10 m.

For Housing 1 (control unit) an attachment kit is available for pipe and wall mounting (see Accessories).

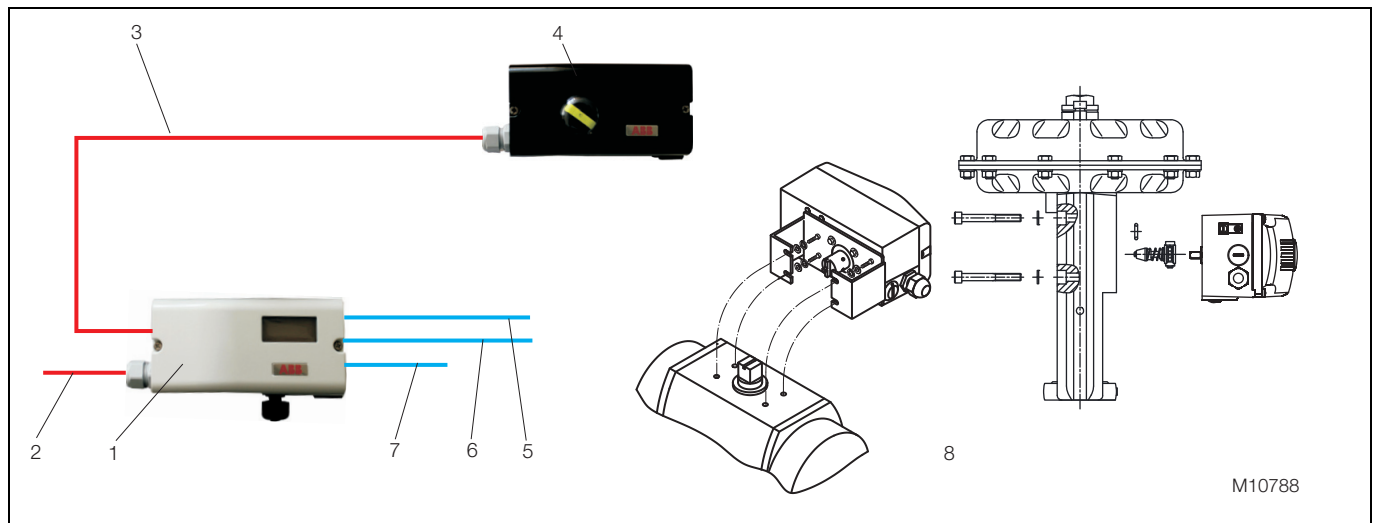

Fig. 9: TZIDC with remote position sensor

- | | |
|-----------------------------|----------------------|
| 1 Housing 1 (control unit) | 5 Pneumatic output 2 |
| 2 Setpoint signal | 6 Pneumatic output 1 |
| 3 Connecting cable | 7 Air supply |
| 4 Housing 2 (remote sensor) | 8 Pneumatic actuator |

7.2 TZIDC for external remote sensor

In the case of the TZIDC design for remote sensor, the positioner is supplied without position detection.

The housing (control unit) contains the electronics and pneumatics along with the following options (where applicable):

- Analog position feedback
- Digital position feedback
- Shutdown module

The TZIDC for remote sensor can be connected to any position sensor (4 k Ω ... 80 k Ω). The maximum cable length is 10 m.

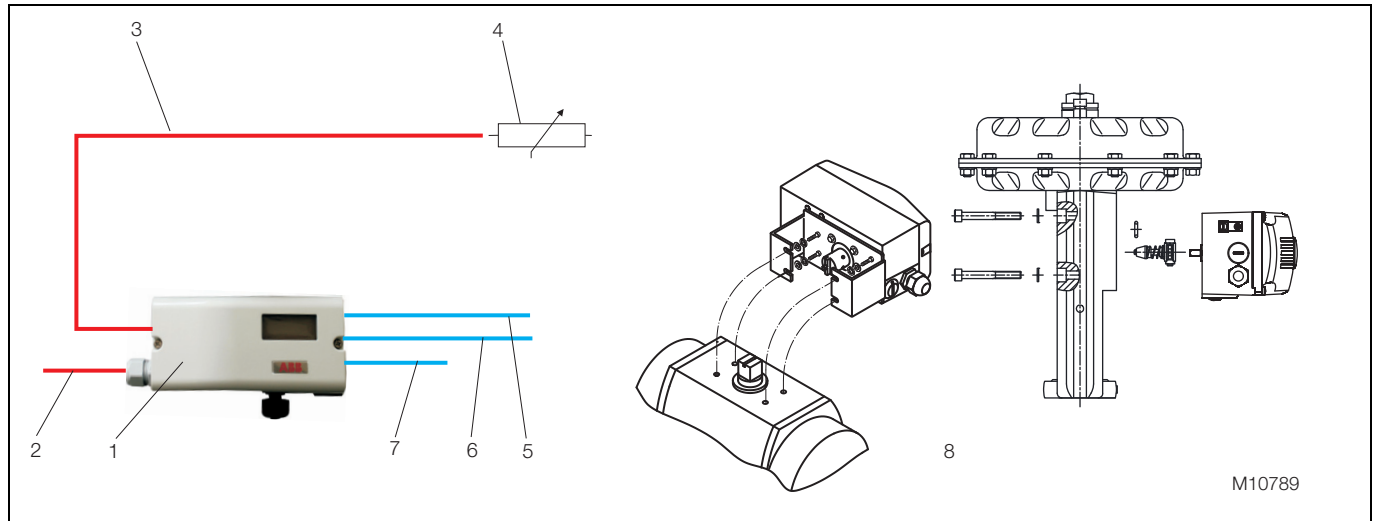
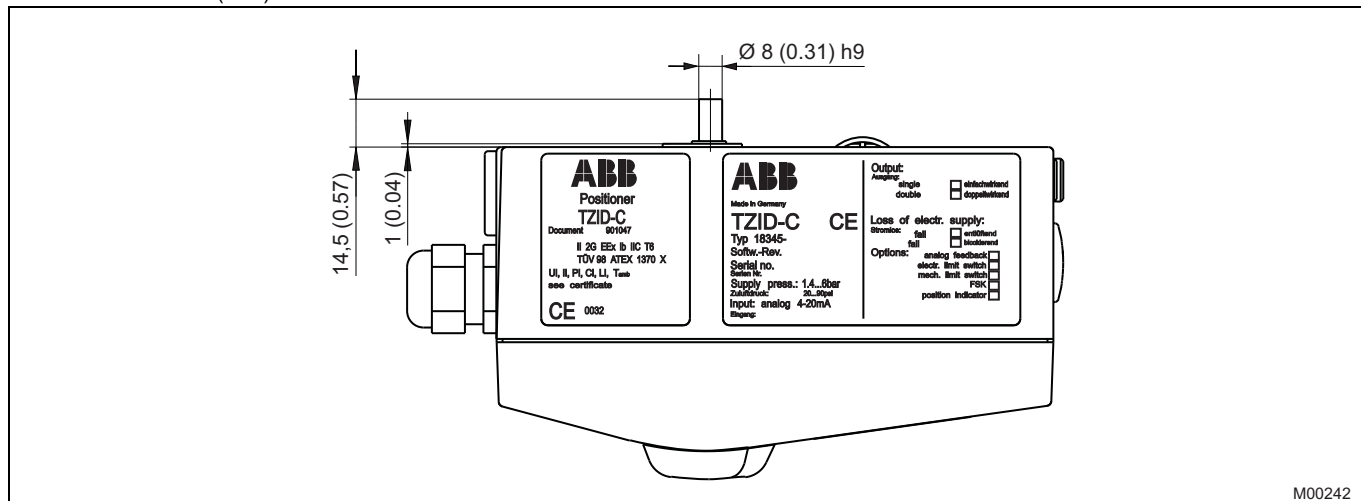

Fig. 10: TZIDC for remote sensor

- | | |
|--------------------------|----------------------|
| 1 Housing (control unit) | 5 Pneumatic output 2 |
| 2 Setpoint signal | 6 Pneumatic output 1 |
| 3 Connecting cable | 7 Air supply |
| 4 Remote sensor | 8 Pneumatic actuator |

8 Dimensions

All dimensions in mm (inch)



M00242

Fig. 11: Top view

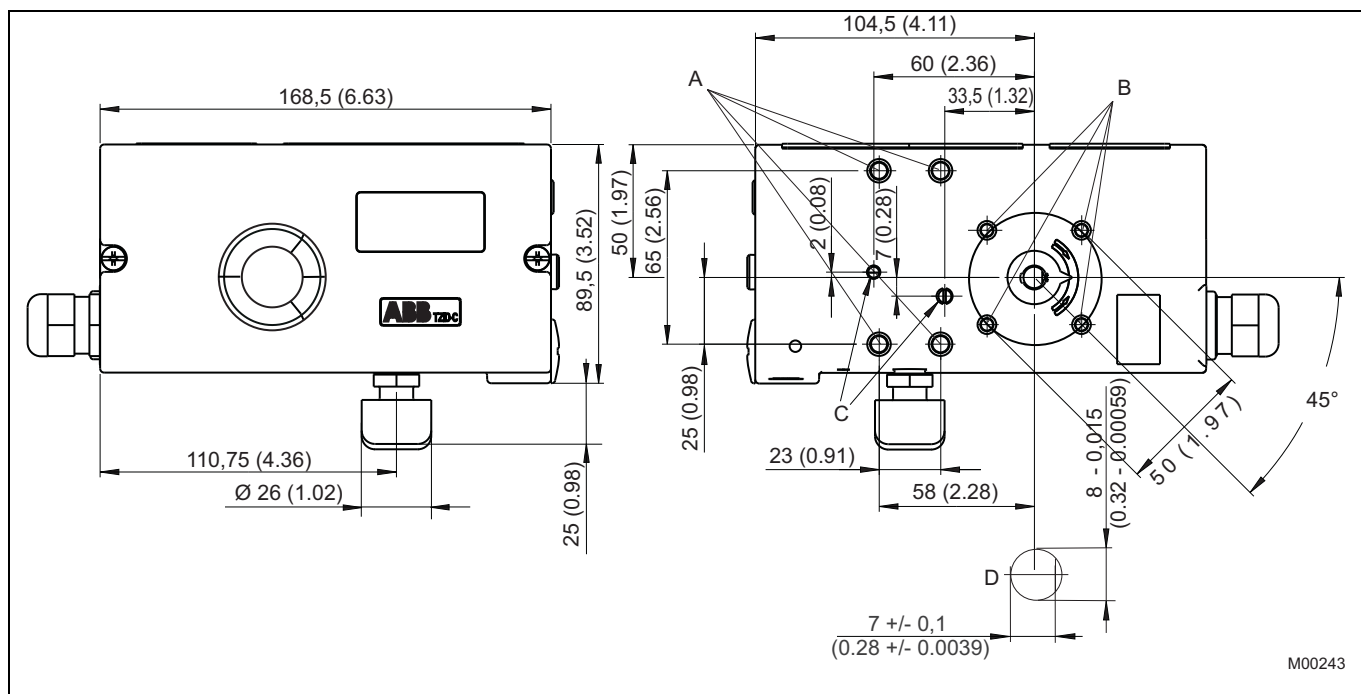

M00243

Fig. 12: Front and rear views

- A Tap hole M8 (10 mm low)
- B Tap hole M6 (8 mm low)

- C Tap hole M5 x 0.5 (air vents for direct mount)
- D Sensor shaft (larger than scale)

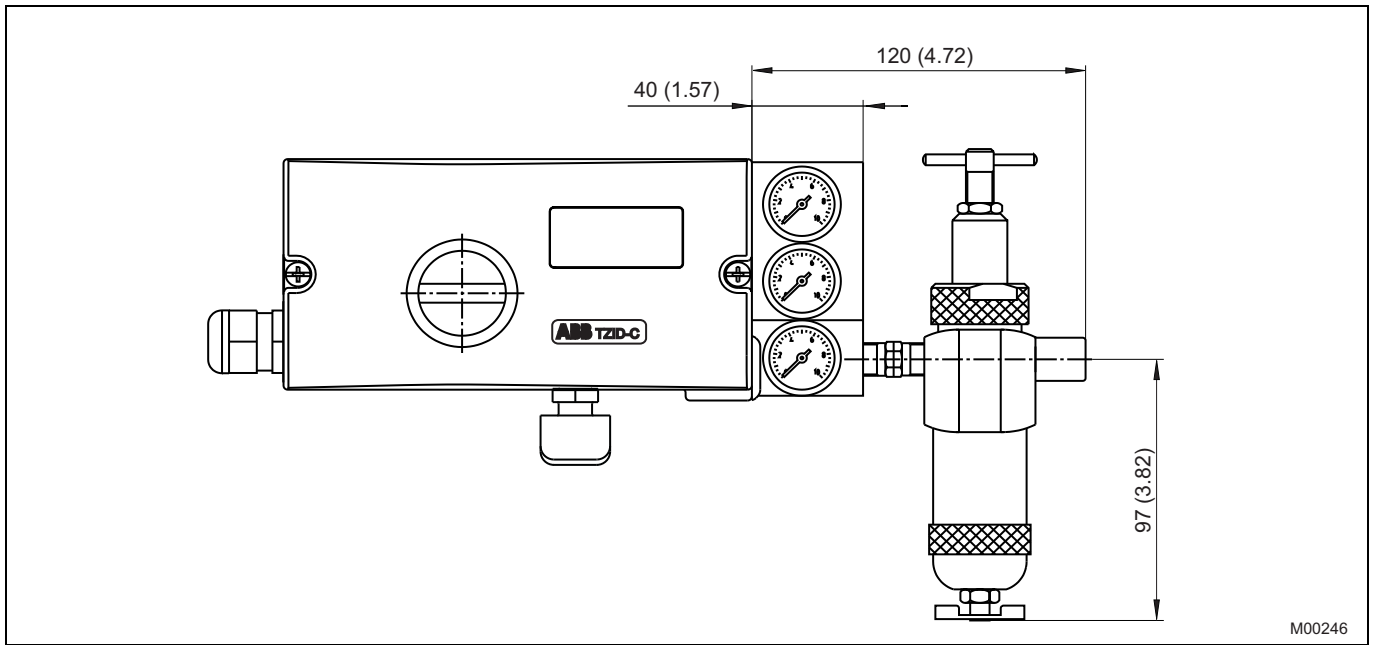

Fig. 15: Positioner TZIDC with pressure gauge block and filter regulator

9 Ordering information

	Main Code											Add. Code			
	Variantenstelle	1 - 6	7	8	9	10	11	12	13	14	15		16		
TZIDC Electro-Pneumatic Positioner, intelligent, configurable, with indicator and operator panel	V18345		X	X	X	X	X	X	X	X	X	X	X	X	XX
Case / Mounting															
Case made of aluminium, varnished, for mounting to linear actuators acc. DIN / IEC 534 / NAMUR or to rotary actuators acc. VDI / VDE 3845			1	0											
Case made of aluminium, varnished, with mechanical position indicator, for mounting to linear actuators acc. DIN / IEC 534 / NAMUR or to rotary actuators acc. VDI / VDE 3845			2	0											
Case made of aluminium, varnished, for integral mounting to control valves (see dimensional drawing)			3	0											
Case made of aluminium, varnished, with mechanical position indicator, for integral mounting to control valves (see dimensional drawing)			4	0											
Case made of aluminium, varnished, for mounting to rotary actuators acc. VDI / VDE 3845 with extended rotation angle up to 270°			5	0											
Case made of aluminium, varnished, with mechanical position indicator, for mounting to rotary actuators acc. VDI / VDE 3845 with extended rotation angle up to 270°			6	0											
Remote sensor control unit	1)		7	0											
Input / Communication Port															
Input 4 ... 20 mA, two-wire, with connector plug for LKS adapter							1								
Input 4 ... 20 mA, two-wire, with connector plug for LKS adapter and FSK module for HART communication							2								
Explosion Protection															
Without							0								
ATEX Ex II 2 G EEx ib II C T6							1								
FM / CSA							2								
ATEX EEx n A II T6							4								
IECEX ib IIC T6							5								
IECEX nA II T6							6								
ATEX Ex II 2 G EEx ia II C T6							7								
ATEX II 2D IP 6X T 51 °C (Zone 21)							8								
GOST Russia - Ex II 2 G EEx ib II C T6							B								
GOST Russia - 0 Ex ia IIC T6							E								
GOST Russia - Ex iaD 21 T5							F								
Output / Safe Position (in case of an electrical power failure)															
Single acting, fail safe							1								
Single acting, fail freeze							2								
Double acting, fail safe							2)	4							
Double acting, fail freeze							2)	5							
Connections															
Cable: Thread 1/2-14 NPT, air pipe: Thread 1/4-18 NPT								2							
Cable: Thread M20 x 1.5, air pipe: Thread 1/4-18 NPT								5							
Cable: Thread M20 x 1.5, air pipe: Thread G 1/4								6							
Cable: Thread G 1/2, air pipe: Thread Rc 1/4								7							

Continued on next page

Main Code.													Add. Code	
Variantenstelle	1 - 6	7	8	9	10	11	12	13	14	15	16	XX		
TZIDC Electro-Pneumatic Positioner, intelligent, configurable, with indicator and operator panel	V18345	X	X	X	X	X	X	X	X	X	X	X	XX	
Option Modules for Analog or Digital Position Feedback														
Without								0						
Plug-in module for analog position feedback, signal range 4 ... 20 mA, two-wire								1						
Plug-in module for digital position feedback								3						
Plug-in module for shutdown function								3)	4					
Plug-in module for analog position feedback, signal range 4 ... 20 mA, two-wire, and digital position feedback								5						
Plug-in module for analog position feedback, signal range 4 ... 20 mA, two-wire, and shutdown module								3)	6					
Plug-in module for analog position feedback, 48 V DC								4)	7					
Optional Mechanical Kit for Digital Position Feedback														
Without									0	0				
Mechanical kit for digital position feedback with proximity switches SJ2-SN (NC or logical 1)								5)	1	0				
Mechanical kit for digital position feedback with proximity switches SJ2-S1N (NO or logical 0)								6)	3	0				
Mechanical kit for digital position feedback with 24 V AC / DC microswitches (change-over contacts)								7)	5	0				
Design (Varnish / Coding)														
Standard													1	
Special version for Chemical Industries													8) E	
SIL2 - Declaration of Conformity														
SIL2 - Declaration of Conformity													9)	CS2
Certificate of Compliance														
Certificate of compliance with the order acc. EN 10204-2.1 (DIN 50049-2.1) with item description														CF2
Test report 2.2 acc. EN 10204 (DIN 50049-2.2)														CF3
Inspection Certificate														
Inspection certificate 3.1 acc. EN 10204														CBA
Device Identification Label														
Stainless steel 11.5 x 60 mm (0.45 x 2.36 in.)														MK1
Sticker 11 x 25 mm (0.43 x 0.98 in.)														MK3
Special Option Cable Gland														
With cable gland														ZG1
Remote Sensor														
Basic unit														RS
Basic unit with position indicator														RD
Remote Sensor Vibration Resistance														
Advanced vibration range 2 g @ 300 Hz														RV
Remote Sensor Protection Class														
Protection class IP 67														RP
Remote Sensor Cable														
5 m cable enclosed														R5
10 m cable enclosed														R6

- 1) With standard characteristic curve, if delivered without remote sensor
- 2) Not for integral mounting
- 3) Not for FM / CSA Version
- 4) Not for explosion protected version
- 5) Only for model with mechanical position indicator, no IECEx
- 6) Only for model with mechanical position indicator and only for ambient temperature range -25 ... 85 °C, no IECEx
- 7) Not for explosion protected version and only for model with mechanical position indicator
- 8) Details on request
- 9) With single acting, fail safe pneumatic only

9.1 Accessories

Accessories	Order number
Mounting bracket	
EDP300 / TZIDC Mounting bracket for rotary actuators (mounting to VDI / VDE 3845), dimension A/B = 80/20 mm	319603
EDP300 / TZIDC Mounting bracket for rotary actuators (mounting to VDI / VDE 3845), dimension A/B = 80/30 mm	319604
EDP300 / TZIDC Mounting bracket for rotary actuators (mounting to VDI / VDE 3845), dimension A/B = 130/30 mm	319605
EDP300 / TZIDC Mounting bracket for rotary actuators (mounting to VDI / VDE 3845), dimension A/B = 130/50 mm	319606
Attachment kit for linear actuators	
EDP300 / TZIDC Attachment kit for linear actuators, stroke 10 ... 35 mm	7959125
EDP300 / TZIDC Attachment kit for linear actuators, stroke 20 ... 100 mm	7959126
Lever	
EDP300 / TZIDC Lever 30 mm	7959151
EDP300 / TZIDC Lever 100 mm	7959152
Adapter	
EDP300 / TZIDC Adapter (shaft coupler) for rotary actuators (mounting to VDI / VDE 3845)	7959110
EDP300 / TZIDC Form - locking shaft adapter	7959371
Pressure gauge block	
TZIDC Pressure gauge block, 0.6 MPa, single acting, G 1/4 connection	7959364
TTZIDC Pressure gauge block, 0.6 MPa, single acting, Rc 1/4 connection	7959358
TZIDC Pressure gauge block, 0.6 MPa, single acting, NPT 1/4 connection	7959360
TZIDC Pressure gauge block, 0.6 MPa, double acting, G 1/4 connection	7959365
TZIDC Pressure gauge block, 0.6 MPa, double acting, Rc 1/4 connection	7959359
TZIDC Pressure gauge block, 0.6 MPa, double acting, NPT 1/4 connection	7959361
Filter regulator	
TZIDC Filter regulator, brass, connections thread G 1/4, incl. material for mounting to pressure gauge block	7959119
TTZIDC Filter regulator, brass, connections thread 1/4-18 NPT, incl. material for mounting to pressure gauge block	7959120
Attachment kit	
EDP300 / TZIDC Attachment kit for Fisher 1051-30, 1052-30	7959214
EDP300 / TZIDC Attachment kit for Fisher 1061 size 130	7959206
EDP300 / TZIDC Attachment kit for Fisher 471	7959195
EDP300 / TZIDC Attachment kit for Fisher 585 C	7959250
EDP300 / TZIDC Attachment kit for Fisher 657 / 667 Size 10 ... 90 mm	7959177
EDP300 / TZIDC Attachment kit for Fisher Gulde 32/34	7959344
EDP300 / TZIDC Attachment kit for Gulde DK	7959161
EDP300 / TZIDC Attachment kit for Keystone 79U/E-002(S) ... 79U/E-181(S)	7959147
EDP300 / TZIDC Attachment kit for Masoneilan CAMFLEX II, VARIMAX, MINITORK II	7959144
EDP300 / TZIDC Attachment kit for Masoneilan VariPak 28000 series	7959163
EDP300 / TZIDC Attachment kit for MaxFlo MaxFlo	7959140
EDP300 / TZIDC Attachment kit for NAF 791290	7959207
EDP300 / TZIDC Attachment kit for NAMUR stroke 100 ... 170 mm	7959339
EDP300 / TZIDC Attachment kit for NELES BC6-20, B1C6-20, BJ8-20, B1J8-20	7959146
EDP300 / TZIDC Attachment kit for Valves Nuovo Pignone, lever for linear stroke, length 150 ... 250 mm	7959210
EDP300 / TZIDC Attachment kit for Samson 241, 271, 3271	7959145
EDP300 / TZIDC Attachment kit for Samson 3277	7959136
EDP300 / TZIDC Attachment kit for Schubert&Salzer GS 8020 / 8021 / 8023	7959200
EDP300 / TZIDC Attachment kit for SED SED stroke 100 mm	7959141

Notes

Notes

Contact us

ABB Limited

Process Automation

Salterbeck Trading Estate
Workington, Cumbria
CA14 5DS
UK

Tel: +44 (0)1946 830 611

Fax: +44 (0)1946 832 661

ABB Inc.

Process Automation

125 E. County Line Road
Warminster, PA 18974
USA

Tel: +1 215 674 6000

Fax: +1 215 674 7183

measurement@us.abb.com

ABB Automation Products GmbH

Process Automation

Schillerstr. 72
32425 Minden
Germany

Tel: +49 551 905-534

Fax: +49 551 905-555

www.abb.com

Note

We reserve the right to make technical changes or modify the contents of this document without prior notice. With regard to purchase orders, the agreed particulars shall prevail. ABB does not accept any responsibility whatsoever for potential errors or possible lack of information in this document.

We reserve all rights in this document and in the subject matter and illustrations contained therein. Any reproduction, disclosure to third parties or utilization of its contents - in whole or in parts - is forbidden without prior written consent of ABB.

Copyright© 2012 ABB

All rights reserved

3KXE341001R1001