

TFE Lined Straight Through Varea-Meter[®] Unit With Magnetic Indicator with Varea-Com[™] Electronic Transmitter

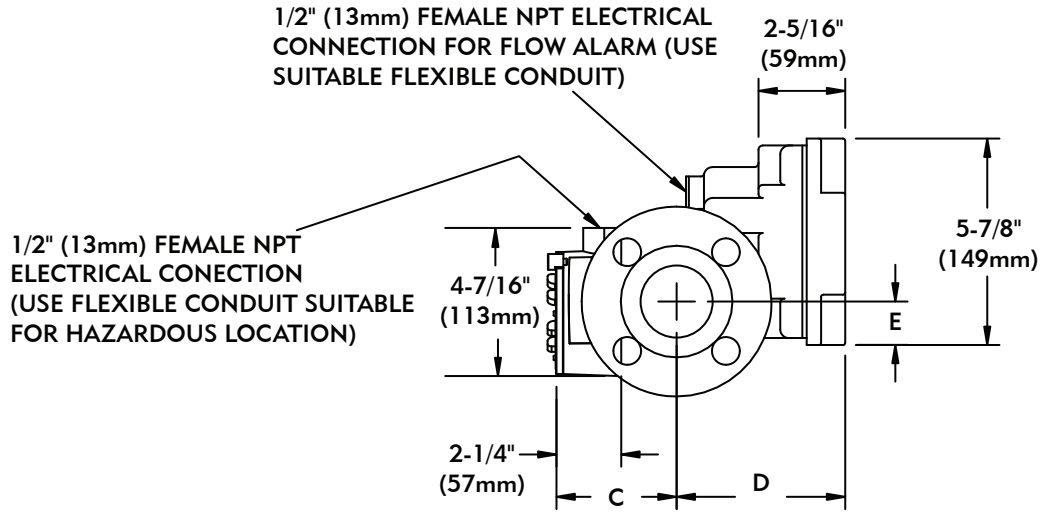

PLAN VIEW

GASKET 5/16" (8mm) THICK
(NOT SHOWN IN PLAN VIEW)

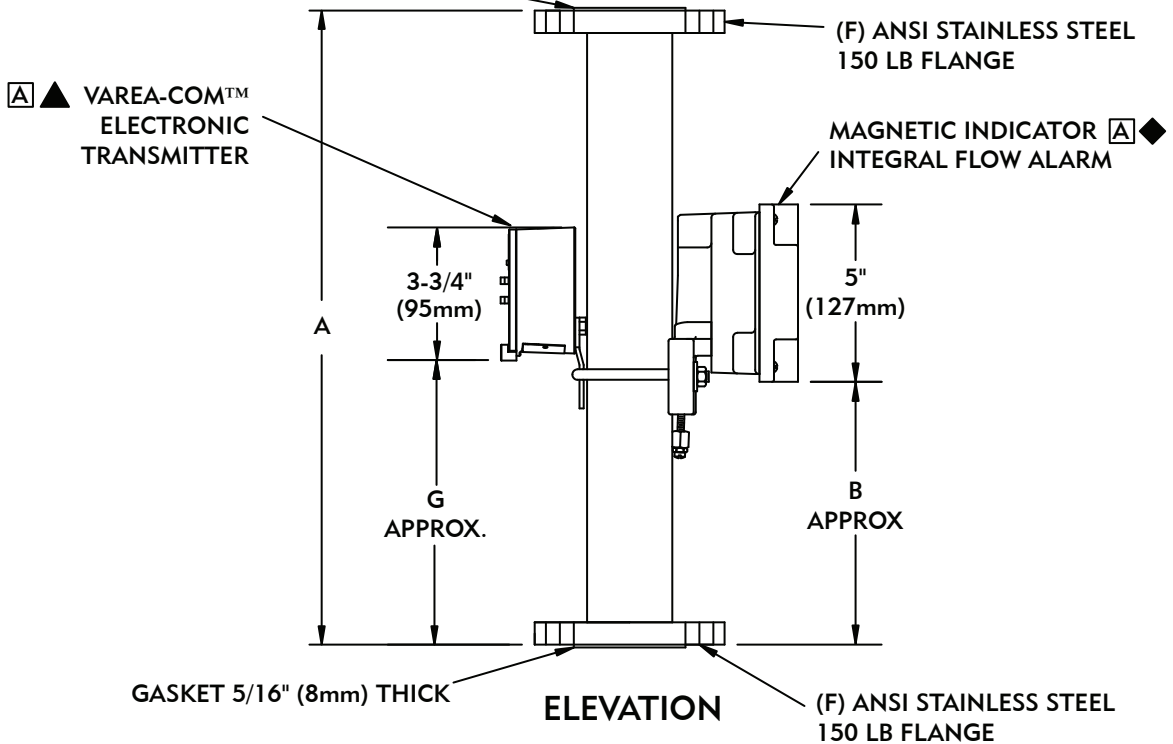

ELEVATION

NOTES:

[A] ACCESSORY ITEM FURNISHED ONLY IF SPECIFICALLY LISTED IN QUOTATION AND AS CHECKED ON THIS DRAWING.

◆ FM APPROVED INTRINSICALLY SAFE FOR CLASS I, DIV I, GROUPS A, B, C, & D WHEN INSTALLED WITH APPROVED BARRIER.

▲ FM APPROVED FOR TYPE 4 DUST IGNITION PROOF, CLASS II, III, DIV I, GROUPS E, F, & G. EXPLOSION PROOF CLASS I, DIV I, GROUPS A, B, C, & D.

SIEMENS

Water Technologies
1901 West Garden Road
Vineland, NJ 08360
856.507.9000 phone
856.507.4125 fax

www.siemens.com/water

Dimensions
WT.520.215.100.UA.CN.1206