

Wallace & Tiernan® Flow Measurement Equipment

Low Flow Meter

SIEMENS

Wallace & Tiernan® low flow variable area flow meters extend the useful range of the rotameter to the measurement of very low flows. They feature a rigid steel frame, positive tube seating and a variety of materials of construction and optional accessories. They combine compactness and accuracy for low flow applications in research and industry.

For higher capacities, write for WT.520.100.000.UA.PS describing the Glass Tube Varea-Meter® Units. For high temperature, high pressure, or hazardous fluid metering, write for publication WT.520.205.000.UA.PS on the Metal-tube Varea-Meter® Units or WT.520.215.000.UA.PS on the TFE-lined and PVC-tube Varea-Meter® Units.

Features

Structurally Strong Frame

The side frames are heavy, channel-form stainless steel sections welded to stainless end fittings turned from bar stock. This produces a rigid unit which resists pipe strains and protects tube alignment.

Choice of Corrosion-Resistant Materials

The frame is made of 302 stainless steel; the end fittings, 316 stainless. The metering-tube retainer is Kynar® vinylidene fluoride resin with 316 stainless optional. O-rings come in a choice of Buna N or Viton® with EPR (ethylene propylene rubber) and Kalrez® optional. Valve trim (seat and stem) is 316 stainless.

Low Flow Meter Flow Measurement



Positive Tube Lock and A Tube Shield

A knurled tube-locking nut, external to the flow, positions the tube retainer and locks the tube firmly in place. Tube removal is quick and easy. O-rings seal the tube at both ends. A clear plastic shield covers the tube. It has tabs which snap into slots in the frame.

Versatile Flow Controller

A Wallace & Tiernan® Flow Controller keeps flow constant regardless of pressure variations. It comes in brass or 316 stainless steel, in inlet or outlet configurations and high or low capacities. Replaceable seat adapters make for easy capacity changes. Straight-through design means the controller can be threaded directly into the meter body, eliminating pipe nipples and static piping.

Key Benefits:

- Rugged, welded frame for superior lifespan of meter
- Wide choice of arrangement and operating positions
- Quick and easy removal of tube and float for cleaning or replacement
- Built-in anti-back flow device
- Smooth and fine adjustment of flow with optional control valve
- Constant flow rate with optional flow controller

Features (Cont'd)

Integral Backcheck

An anti-backflow device is built into the discharge. It consists of a 316 stainless steel poppet with a Buna N or Viton® O-ring seal. This allows easy maintenance on tube and float.

High Interchangeability

Tubes have same size O-rings at each end. The tubes for all capacities fit one frame size. This and the one-piece frame make for design simplicity with simplified maintenance and spare parts stocking.

Choice of Arrangements and Operating Position

Low Flow Meters can be supplied with: an integral flow control valve with a screwdriver-slot stem or a knob for adjustment; a factory-connected flow controller to maintain flows constant; and a plastic bezel for flush panel mounting. The meter can be inverted and its tube reversed to change the control valve from the inlet to the discharge.

Versatile Control Valve

The optional control valve has a common stem with high- or low-capacity seats; all are 316 stainless. An O-ring in the seat makes it easy to change. The valve gives smooth adjustment and a fine degree of control.

Technical Data

Accuracy: 2% of full scale.

Operating Range: 10 to 1.

Pipe Connections

1/4-inch female NPT at meter inlet and outlet, at control valve inlet, and at flow controller inlet; horizontal in and horizontal out.

Mounting

In-line; wall through mounting holes in the back of the frame; flush panel with optional bezel.

Scales

Scale length is 6 inches, standard calibrations as shown in tables B and C.

Pressure and Temperature Limits

Temperature and pressure are interdependent but the following limits must not be exceeded under any conditions.

TUBE RETAINER	O-RINGS	PRESS. PSIG (Bar)	TEMP. °F (°C)
Kynar®	All	200 (14)	200 (93)
316 SS	Buna N	250 (17)	250 (121)
316 SS	Viton®	250 (17)	250 (121)
316 SS	EPR	250 (17)	250 (121)
316 SS	Kalrez®	250 (17)	250 (121)

Write for WT.500.001.000.UA.CG, which is a detailed listing of this meter's compatibility with a wide range of fluids.

Special Calibration

Excluding extra low capacities. Scales calibrated in other than the standard units in Tables B and C are available at extra cost.

Materials of Construction

Frame	302 Stainless
Tube	Borosilicate glass
Float	See Tables B and C
O-Rings	Buna N or Viton® with Kalrez® or EPR (optional)
Tube Retainer	Kynar®, 316 Stainless (optional)
Lock Nut	Kynar®
Flow Insert	Kynar® (Used with high capacity air meters only)
Tube Shield	Polycarbonate
End Fittings, Check Valve, Pipe Plug, Poppet & Valve Trim/ Adapter/Retainer	316 Stainless

Shipping Weights

Meter only, 1 lb.; Meter with control valve, 2 lbs.; Panel mounting bezel, 3 lbs.

Accessories

Flow Controllers

Meters with control valves and Wallace & Tiernan® Flow Controllers are designed to give reliable flow control, regardless of pressure changes. For liquid service, specify inlet type from Table 5. For gas service with varying upstream and constant downstream pressures, specify inlet type. For gas service with constant upstream and varying downstream pressures, specify outlet type. Meters with flow controllers are tested and shipped assembled. (Write for WT.570.100.000.UA.PS.)

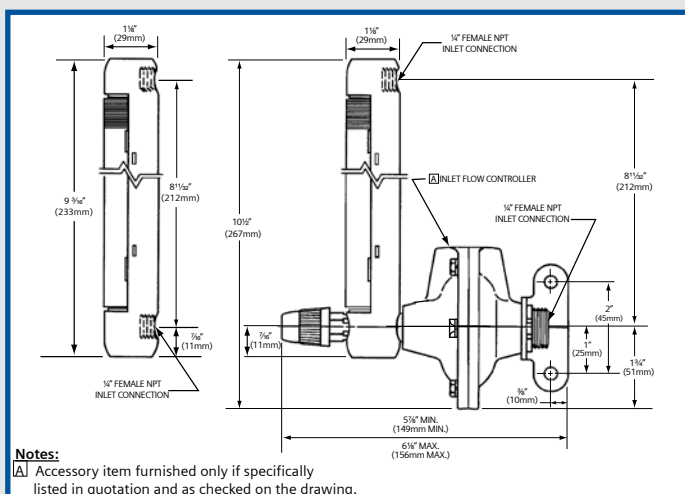

Selection Procedure

Determine the capacity range, temperature and pressure capability, materials of construction, and options required for each meter. See Technical Data Section for pressure and temperature limits.

Note: For fluids with SP.GR. other than 1.0 or viscosity other than 1.0 CSS consult your local Varea-Meter® Products Distributor.

TABLE A – ORDERING NUMBERS FOR BASIC METER ARRANGEMENTS

CAPACITY	FUNCTION	316 STAINLESS END FITTINGS		
		BUNA N/ KALREZ®/EPR O-RINGS	VITON® O-RINGS	
EXTRA LOW 1.9 ccm H ₂ O or 130 sccm air maximum	METER ONLY	20	30	
	METER WITH CONTROL VALVE	NOT AVAILABLE		
LOW 2.7 GPH H ₂ O or 14 scfh air maximum	METER ONLY	20	30	
	METER WITH CONTROL VALVE	VALVE TRIM	316 SS	316 SS
		WITH KNOB	22	32
WITH SLOT	26	36		
HIGH 40 GPH H ₂ O or 115 scfh air maximum	METER ONLY	20	30	
	METER WITH CONTROL VALVE	VALVE TRIM	316 SS	316 SS
		WITH KNOB	24	34
WITH SLOT	28	38		

TABLE B – ORDERING NUMBERS FOR TUBES, FLOATS AND SCALES – WATER

	MAX. CAPACITY AND SCALE UNITS	TUBE, SCALE AND FLOAT NUMBER	FLOAT MATERIAL
EXTRA LOW CAPACITY	0.375 ccm 0-100%	- C016	Sapphire
	0.875 ccm 0-100%	- C026	316 SS
	1.9 ccm 0-100%	- C036	Tantalum
	- 7.0 ccm 0-100%	- B046 C046	Black Glass
	0.5 gph 32 ccm 0-100%	A056 B056 C056	316 SS
LOW CAPACITY	- 66 ccm 0-100%	- B066 C066	Black Glass
	2.7 gph 170 ccm 0-100%	A076 B076 C076	316 SS
	8.4 gph 540 ccm 0-100%	A086 B086 C086	316 SS
	15.0 gph 960 ccm 0-100%	A096 B096 C096	316 SS
	26.0 gph 1650 ccm 0-100%	A106 B106 C106	316 SS
HIGH CAPACITY	40.0 gph 2600 ccm 0-100%	A116 B116 C116	Tantalum

TABLE C – ORDERING NUMBERS FOR TUBES AND FLOATS – AIR

	MAX. CAPACITY AND SCALE UNITS	1/2" SCALE LENGTH	FLOAT MATERIAL
EXTRA LOW CAPACITY	50 sccm 0-100%	- D016	Sapphire
	80 sccm 0-100%	- D026	316 SS
	130 sccm 0-100%	- D036	Tantalum
	1.2 scfh 0-100% (2 scmh)	E046 D046	Black Glass
	2.7 scfh 0-100% (4.6 scmh)	E056 D056	316 SS
LOW CAPACITY	7.0 scfh 0-100% (12 scmh)	E066 D066	Black Glass
	14.0 scfh 0-100% (24 scmh)	E076 D076	316 SS
	21.0 scfh 0-100% (36 scmh)	E086 D086	Black Glass
	40.0 scfh 0-100% (68 scmh)	E096 D096	316 SS
	60.0 scfh 0-100% (102 scmh)	E106 D106	316 SS
HIGH CAPACITY	115.0 scfh 0-100% (195 scmh)	E116 D116	316 SS

NOTE: For special calibrations of low and high capacity meters, the first digit of the tube, float and scale code is an L for liquid service and a G for gas service.

WARNING: Do not use Glass-Tube Meters for fluids which are toxic, hazardous or attack glass.

Ordering Procedure

Example

To order a low capacity meter with control valve with knob, 316 stainless trim and Buna N O-rings, specify 22. To order a tube with a capacity of 32 ccm

water and scale units in ccm add B056. Add S for standard O-ring material. Add S for standard Kynar tube retainer. Add X for no flow controller, 2 for bezel to

accommodate meter with control valve, and 2 for control valve at meter inlet. Add X for no tag. Thus the complete ordering number is: **22 B056 SS X 2 2 X.**‡



1 - Basic Meter Arrangement

From Table A			
<input type="checkbox"/> 20	<input type="checkbox"/> 26	<input type="checkbox"/> 32	<input type="checkbox"/> 38
<input type="checkbox"/> 22	<input type="checkbox"/> 28	<input type="checkbox"/> 34	
<input type="checkbox"/> 24	<input type="checkbox"/> 30	<input type="checkbox"/> 36	

2 - Tube, Scales and Float

From Table B (water) or C (air)

3 - O-Ring Material

Code	Description
S	Buna N or Viton® (standard - from Table A)
1	EPR (optional)
K	Kalrez® (optional)

Note: See Tech. Data for Press. & Temp. limits.

4 - Tube Retainer Material

Code	Description
S	Kynar® (standard)
1	316 Stainless Steel (optional)

5 - Flow Controller (optional)

	Capacity	Connection	Model	Code
316 S.S.	30 scfh-5 gph	¼" NPT inlet	5810	S
	30 scfh-5 gph	¼" NPT outlet	5820	T
	193 scfh-40 gph	¼" NPT inlet	5850	U
	193 scfh-40 gph	¼" NPT outlet	5860	Y
BRASS	30 scfh-5 gph	¼" NPT inlet	5830	N
	30 scfh-5 gph	¼" NPT outlet	5840	P
	170 scfh-40 gph	¼" NPT inlet	5870	Q
	193 scfh-40 gph	¼" NPT outlet	5880	R
	NONE			X

*Flow controller location must be same as valve location (inlet/outlet).

6 - Bezel (optional)

Code	Description
1	Bezel (without control valve)
2	Bezel (with control valve)
X	None

Note: Available only for 3" Scale Length Meter

7 - Control Valve Location (optional)

Code	Description
X	No Valve
2	Inlet Valve
3	Outlet Valve

8 - ID Tag (optional)

Code	Description
X	None
1	Stainless Steel

‡ Note: Your order number should consist of 12 characters.

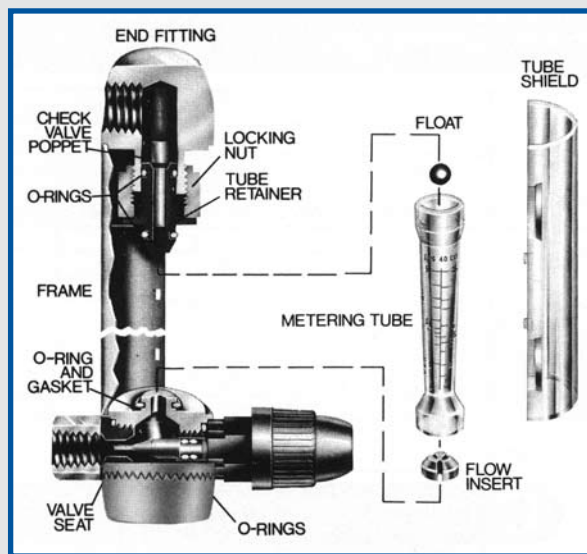

The information provided in this brochure contains merely general descriptions or characteristics of performance which in case of actual use do not always apply as described or which may change as a result of further development of the products. An obligation to provide the respective characteristics shall only exist if expressly agreed in the terms of contract.

Wallace & Tiernan and Varea-Meter are trademarks of Siemens, its subsidiaries or affiliates. Viton and Kalrez are trademarks of DuPont Performance Elastomers, LLC. Kynar is a trademark of Arkema Inc.

Siemens
 Water Technologies
 1901 West Garden Road
 Vineland, NJ 08360
www.siemens.com/wallace-tiernan
wtus.water@siemens.com

Lit. No.: WT.510.150.000.UA.PS.0807
 Tel: 856.507.9000
 Fax: 856.507.4125
 Subject to change without prior notice
 ©2007 Siemens Water Technologies Corp.