

1/2" By-Pass Metal-Tube Varea-Meter® Unit With Magnetic Indicator

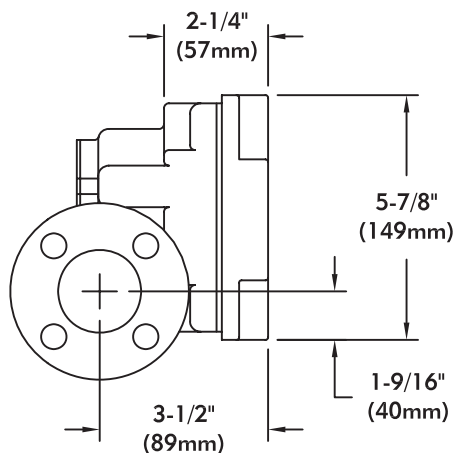

PLAN VIEW

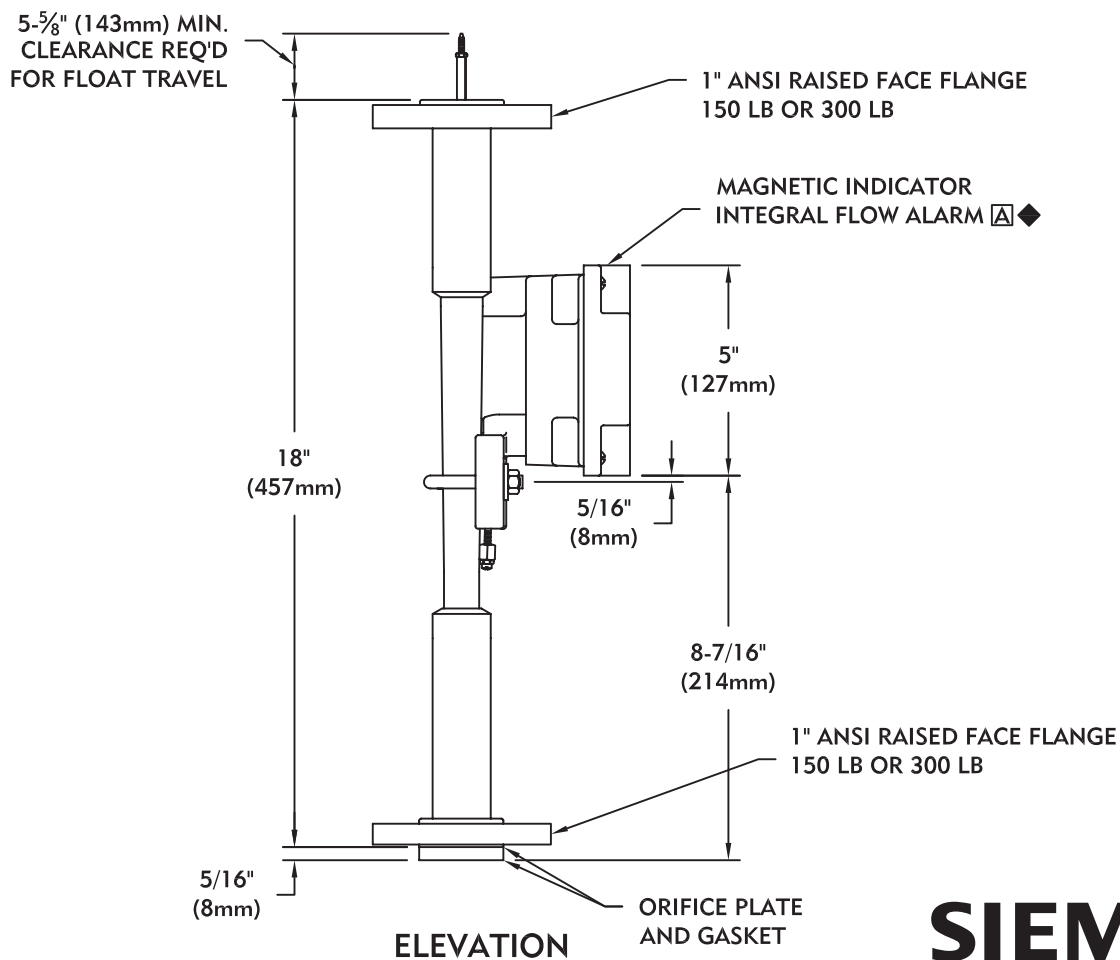

ELEVATION

SIEMENS

NOTES:

- ☐ ACCESSORY ITEM FURNISHED ONLY IF SPECIFICALLY LISTED IN QUOTATION AND AS CHECKED ON THIS DRAWING.
- ◆ FM APPROVED INTRINSICALLY SAFE FOR CLASS I, DIV I, GROUPS A, B, C, & D WHEN INSTALLED WITH APPROVED BARRIER.

Water Technologies
1901 West Garden Road
Vineland, NJ 08360
856.507.9000 phone
856.507.4125 fax

www.siemens.com/water

Dimensions
WT.520.300.100.UA.CN.1206