

# Series 55-200 Armored Flowmeter With Magnenetic Indicator

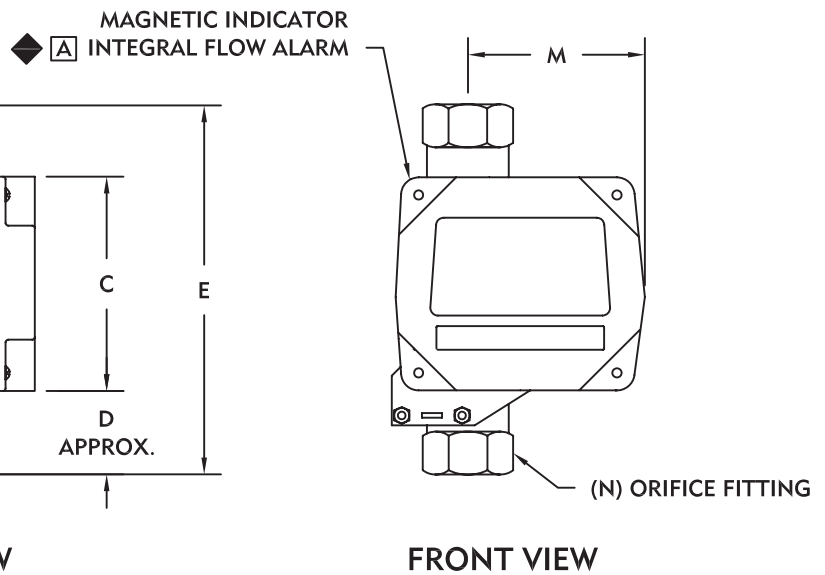
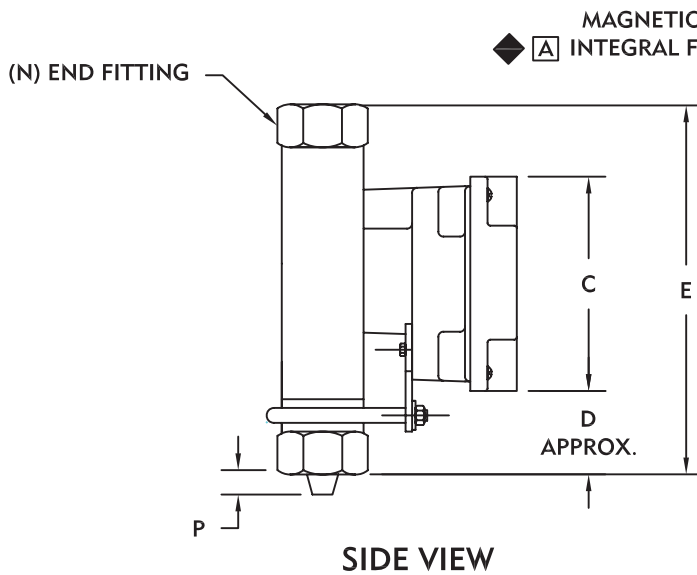
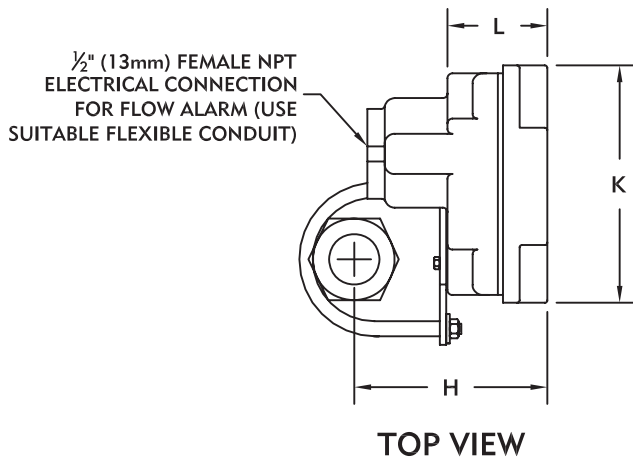

**NOTES:**

▲ ACCESSORY ITEM FURNISHED ONLY IF SPECIFICALLY LISTED IN QUOTATION AND AS CHECKED ON THIS DRAWING.

◆ FM APPROVED INTRINSICALLY SAFE FOR CLASS 1, DIV 1, GROUPS A, B, C, & D WHEN INSTALLED WITH APPROVED BARRIER.

# SIEMENS

TUBE SIZE	C	D	E	H	K	L	M	N	P
1/2" (13mm)	5" (127mm)	1-13/16" (46mm)	7-1/2" (191mm)	4-3/16" (106mm)	5-7/8" (149mm)	2-1/4" (57mm)	3-3/4" (95mm)	1/2" NPT	—
1" (25mm)	5" (127mm)	2" (51mm)	8-15/16" (227mm)	4-1/2" (114mm)	5-7/8" (149mm)	2-1/4" (57mm)	4-5/16" (110mm)	1" NPT	5/16" (8mm)
1-1/2" (38mm)	5" (127mm)	2-3/4" (70mm)	11-5/8" (295mm)	5" (127mm)	5-7/8" (149mm)	2-1/4" (57mm)	4-3/16" (116mm)	1-1/2" NPT	1" (25mm)
2" (51mm)	5" (127mm)	3" (76mm)	12-7/8" (327mm)	5-7/16" (138mm)	5-7/8" (149mm)	2-1/4" (57mm)	5" (127mm)	2" NPT	1-3/8" (35mm)

Water Technologies  
 1901 West Garden Road  
 Vineland, NJ 08360  
 856.507.9000 phone  
 856.507.4125 fax

[www.siemens.com/water](http://www.siemens.com/water)

Dimensions  
 WT.550.200.100.UA.CN.1206