

# Arma-View® II Low Flow Armored Purge Meter With Explosion Proof Transmitter

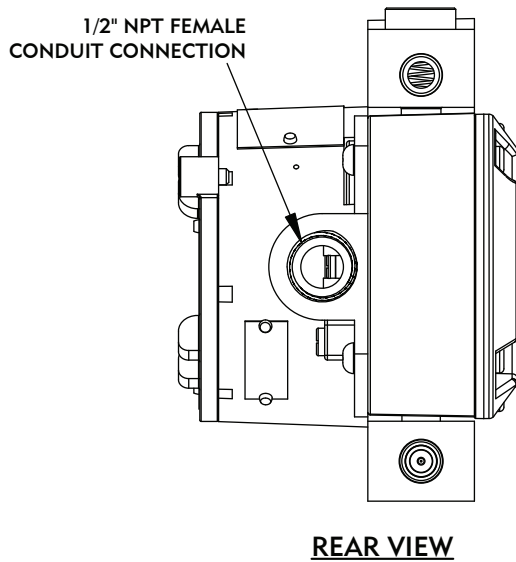
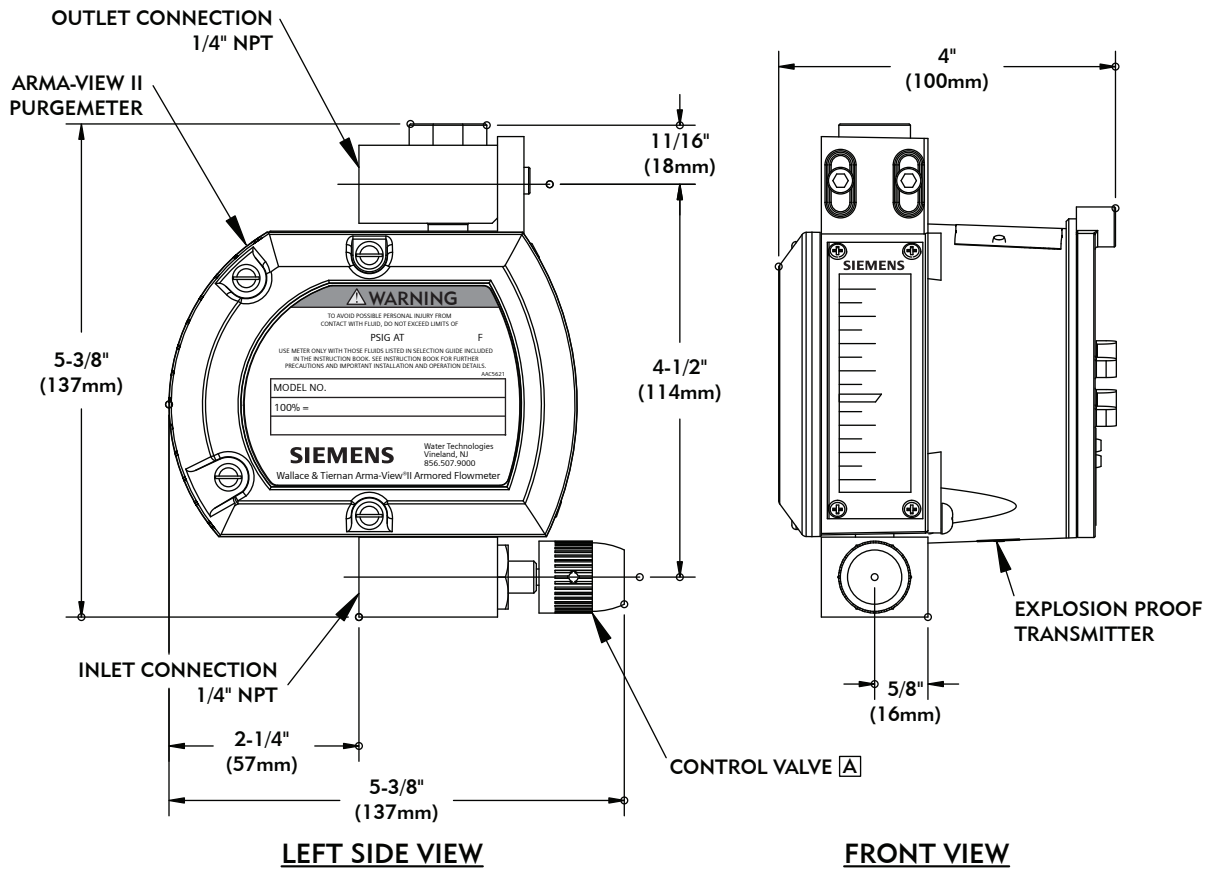

**NOTE:**  
**A** ACCESSORY ITEM FURNISHED ONLY IF SPECIFICALLY LISTED  
 IN QUOTATION AND AS CHECKED ON THIS DRAWING.

# SIEMENS

Water Technologies  
 1901 West Garden Road  
 Vineland, NJ 08360  
 856.507.9000 phone  
 856.507.4125 fax

[www.siemens.com/water](http://www.siemens.com/water)

Dimensions  
 WT.510.260.106.UA.CN.1206