

Model 105/106 Differential Pressure Gauge

LOW RANGE: 0-10" H₂O to 0-400" H₂O (25 mbar to 1 bar)



The Model 105/106 diaphragm/bellows design provides a simple, compact, accurate, direct-acting, low range differential pressure indicator.

- Working pressures of 500, 1500, 3000, or 6000 psig (400 bar) are available in the same housing size. The gauges are cost efficient, light weight and easy to install.
- Aluminum, Brass, Carbon Steel, or 316 Stainless Steel housings with a choice of Copper-Alloy or Stainless Steel diaphragm/bellows and a wide variety of elastomers. The materials of construction can easily be matched to the application.
- Mechanical over-range protection high to low and low to high. The Models 105/106 gauges require no additional "fill" liquid in their over-range system, eliminating the possibility of system contamination. The gauge is easier and less expensive to service/repair than competitive units.
- Uni-directional or bi-directional dials are readily available. Offers the ability to read positive or positive/negative differential pressure with one gauge.
- Gauges are optionally available with one or two switches. Offers the ability to have alarm or control.
- The Models 105/106 come with a five year limited warranty on gauge workmanship and materials, with a one year warranty on switch options. Provides a quality product with the long term security of a product warranty.

MODEL 105/106 CHARACTERISTICS

The major components of the Model 105/106 are a two-piece body, a multiple diaphragm/bellows sensing element and over-pressure assembly, a torque tube assembly, a range spring and the gauge front assembly.

The body halves provide the pressure containment function. They also clamp the sensing element and over-pressure assembly between the halves, isolating the high side and low side pressures of the system. The high side body half also provides a mount for the torque tube assembly and the gauge front assembly.

The sensing element is exposed to the differential pressure and deflects in response to the differential pressure. This assembly incorporates a bi-directional relief valve which provides over-pressure protection in both directions. When over-pressured from the high side, the valve is opened by a mechanical stop as the sensing element deflects to its maximum travel. When over-pressured from the low side, the spring-loaded valve opens when the differential pressure exceeds its maximum rating. The opening of the valve in either direction equalizes the pressure and protects the unit.

A range spring is provided to adjust the spring rate of the system to suit the various differential pressure ranges of the instrument.

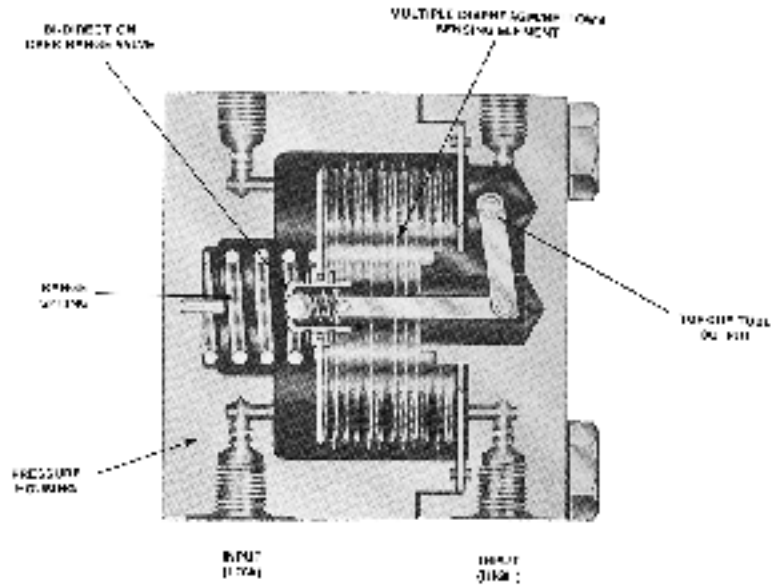

TYPICAL CROSS SECTION

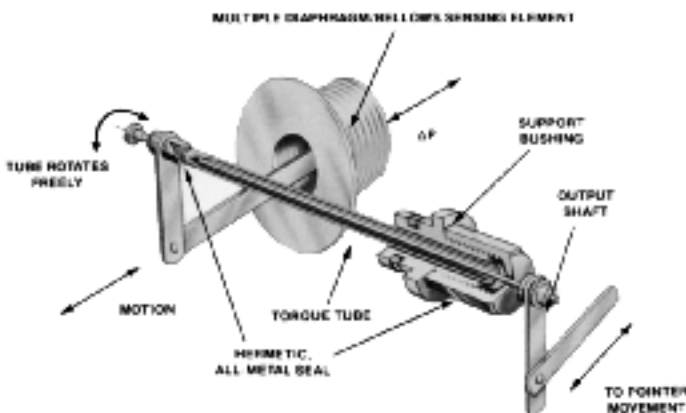

TORQUE TUBE ASSEMBLY

The torque tube assembly consists of a rigid shaft and torque tube. The torque tube is welded to a bushing which is fixed to the high side pressure body half. The other end of the tube is welded to the shaft. The shaft is connected to the sensing element by a linkage. As the sensing element deflects, it causes the torque tube to twist. The torque tube provides a frictionless transmission of an output which is proportional to the differential pressure.

The torque tube shaft extends into the gauge front assembly and is connected to a low-friction, jeweled movement which provides output to the pointer.

"LOCKED LOGIC" SOLID STATE ALARM-CONTROL FOR ALL 105, 106 GAUGES (NOTE - 6" DIAL SIZE ONLY)



If your application requires switching in addition to local indication, our all solid state "Locked Logic" system is the most accurate available. With no moving cams, levers, etc. it does not affect the accuracy of the gauge on which it is installed. Switch accuracy is the same as the gauge accuracy.

Visible set pointers are provided, adjustable to within 5% of full scale of each other. The set points are adjustable from 5 to 95% of full scale. Internal adjustment is standard.

STANDARD MODEL SPECIFICATIONS

105-CE-00-00

1500 P.S.I.G./Working Pressure Aluminum Body & Copper Alloy Internals; 6" Uni-Directional Dial $\pm 1\%$ Full Scale Accuracy; Buna N Seals, 1/4" FNPT Connections (Dual-Top & Bottom).
Weather resistant engineering plastic case & shatter resistant acrylic lens.

PART NUMBERING SYSTEM

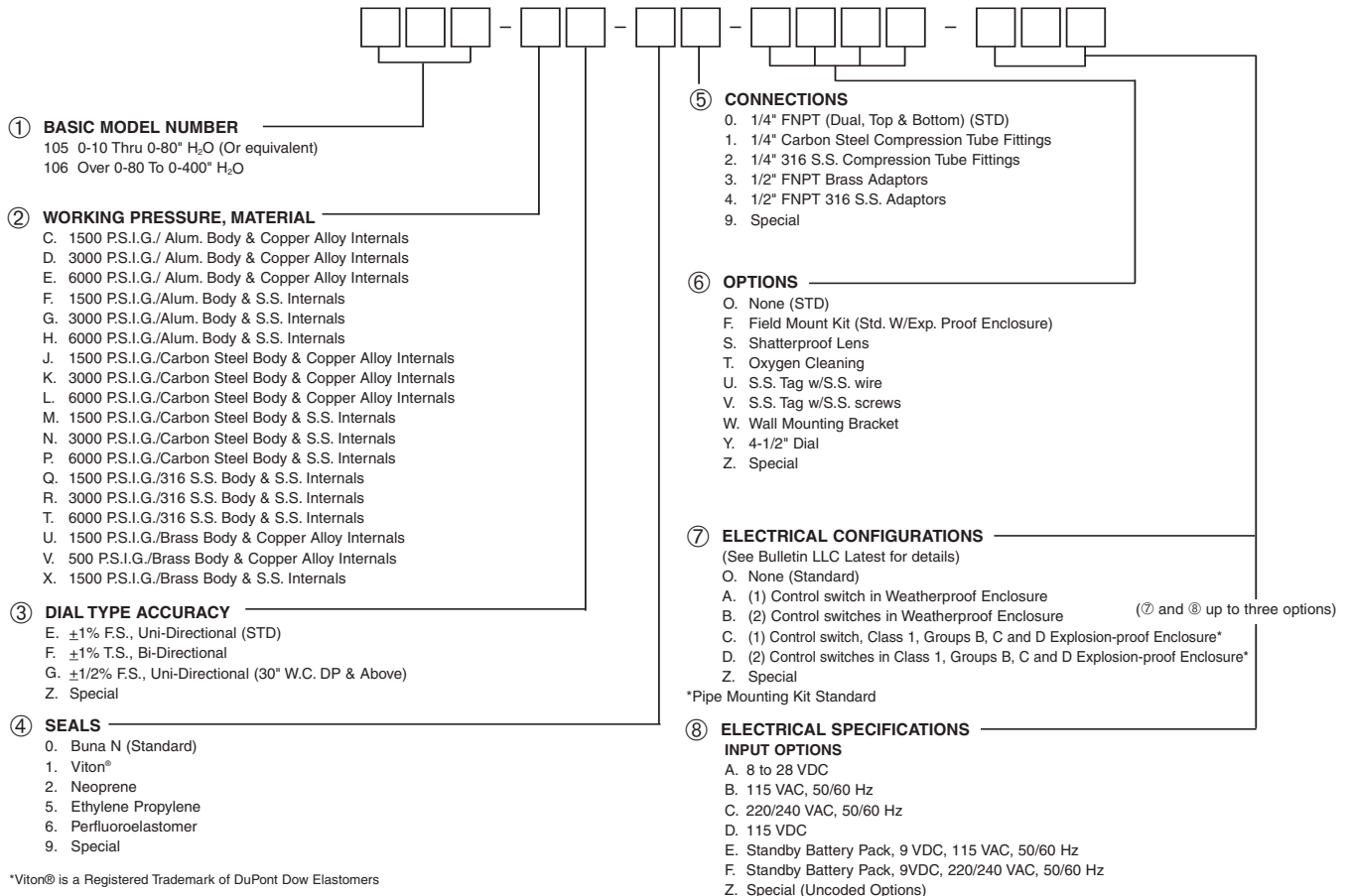

*Viton® is a Registered Trademark of DuPont Dow Elastomers

NOTE: The use of diaphragm seals is not recommended for model 105/106 series gauge. Attempts to install such seals on these gauges will void the warranty.

NOTE: NOT ALL OPTIONS AVAILABLE IN COMBINATION WITH OTHER OPTIONS

MOUNTING INFORMATION & DIMENSIONAL DATA

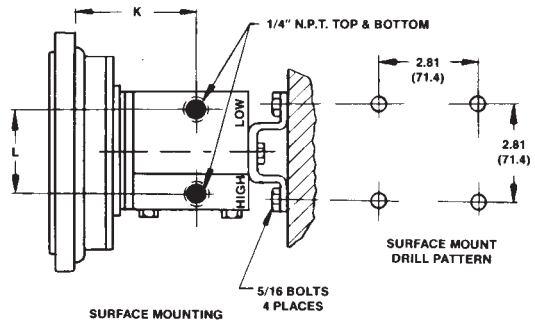
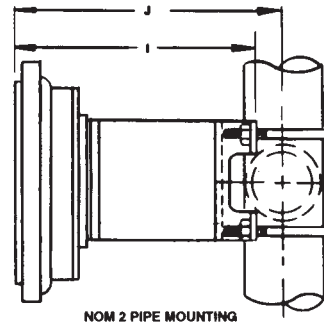
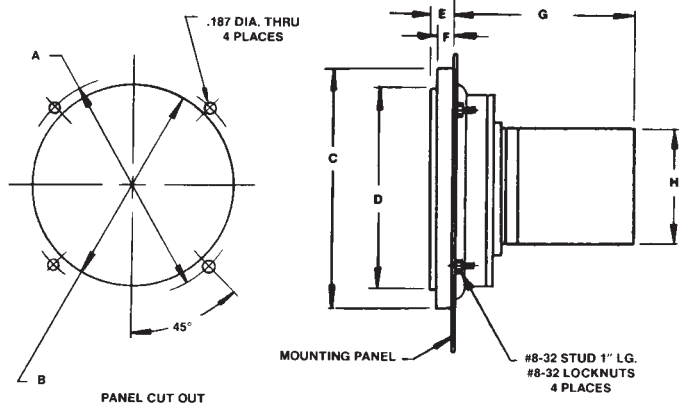

MODEL	A	B	C	D	E	F	G	H	I	J	K	L
105-4½"	5.63 (143.0)	5.29 (134.3)	6.21 (157.7)	5.25 (133.3)	.85 (21.4)	.70 (17.6)	4.88 (123.9)	3.75 (95.2)	6.90 (177.2)	7.62 (193.7)	3.00 (76.2)	2.43 (62.0)
105-6"	7.00 (177.8)	6.50 (165.1)	8.18 (208.0)	6.94 (176.2)	.91 (23.1)	.76 (19.3)	4.88 (123.9)	3.75 (95.2)	7.02 (178.5)	7.74 (196.7)	3.00 (76.2)	2.43 (62.0)
106-4½"	5.63 (143.0)	5.29 (134.3)	6.21 (157.7)	5.25 (133.3)	.85 (21.4)	.70 (17.6)	4.40 (111.7)	3.00 (76.2)	6.42 (163.2)	7.14 (181.5)	3.00 (76.2)	2.43 (62.0)
106-6"	7.00 (177.8)	6.50 (165.1)	8.18 (208.0)	6.94 (176.2)	.91 (23.1)	.76 (19.3)	4.40 (111.7)	3.00 (76.2)	6.54 (166.3)	7.26 (184.5)	3.00 (76.2)	2.43 (62.0)

- NOTES: 1. Drawings show standard gauge nominal dimensions. (not to scale)
 2. Dimensions shown in parentheses are in millimeters.
- NOTES: 1. Drawings show standard gauge nominal dimensions. (not to scale)
 2. Dimensions shown in parentheses are in millimeters.

Manufacturer reserves the right to change specifications without prior notice.

PROOF PRESSURE: Two times working pressure or 10,000 PSI whichever is lower at ambient temperature.

TEMPERATURE LIMITS: -40°F(-40°C) to +200°F(+93°C) - These limits are based on the entire instrument being saturated to these temperatures. System (process) temperatures may exceed these limitations with proper installation. Contact our customer service representative for details.

STANDARDS: All Model 105/106 Series gauges either conform to and/or are designed to the requirements of the following standards:

- | | |
|----------------------------|------------------------------|
| ASME B1.20.1 | NACE MR0175 |
| ASME B40.1 | NEMA Std. No. 250 |
| CSA-C22.2 No. 14.25 and 30 | SAE J5141 |
| | UL Std. No. 50, 508 and 1203 |

**Mid-West
Instrument**®

6500 Dobry Dr. □ Sterling Heights, MI 48314
 (586) 254-6500 □ FAX (586) 254-6509
 E-mail: sales@midwestinstrument.com
 Website: www.midwestinstrument.com

Printed in U.S.A.



REPRESENTED BY: